

M133K, 13.3-inch Ultra Rugged Tablet

An Ultra Rugged Tablet that Can Survive Any Environment and Get Real Work Done

M133K is the next generation of the 13.3-inch rugged tablet with robust set of features designed to withstand industrial use while providing high tech solutions that increase productivity, improve safety, and reduce operational costs. The processing power comes from Intel's 7th generation Core i5-7200U Kaby Lake processor and the tablet features a brilliant, wide viewing angle with direct optical bonding, projected capacitive touch screen, which is outdoor viewable and offers a 1920 x 1080 resolution display. Equipped with a built-in kickstand, the M133K is a powerful workstation with reliable performance in a mobile and ultra-rugged design.



Highlights

- Intel® Core™ i5-7200U Kaby Lake, 2.5 GHz (Turbo up to 3.10 GHz)
- 13.3" 1920 x 1080 wide viewing angle LED panel with optical bonding
- Optional high brightness 800 nits
- PCAP touch with anti-glare (AG) technology
- Magnesium alloy housing with all-around elastomeric rubber
- Built-in kickstand
- Optional hot-swappable user-replaceable battery
- IP65 waterproof and dustproof

M133K, 13.3-inch Ultra Rugged Tablet

An Ultra Rugged Tablet that Can Survive Any Environment and Get Real Work Done

Display Specification

Size	13.3-inch
Resolution	1920 x 1080
Brightness	500 nits with Optical Bonding (Optional 800 nits)
Touch	Multi-touch Projected Capacitive with Glove/Rain/Stylus Modes Active Stylus Support
Contrast Ratio	1000:1
Viewing Angle	89/89/89/89
Technology	<ul style="list-style-type: none">Intel HD Graphics (built-in CPU) video controllerAnti-glare technology (Default)

System Specification

Processor	Intel® Core™ i5-7200U Kaby Lake, 2.5 GHz (Turbo up to 3.10 GHz)
System Memory	4GB SODIMM DDR4-2400 (up to 16GB) ¹
Storage 1	1 x 128GB M.2 SSD (up to 512GB)
Storage 2	Optional M.2 SSD (up to 512GB)
Operating System	Windows 10 IoT Enterprise
Sensors	Light sensor/ G sensor / Gyro / E-compass

Wireless Communication

WLAN	802.11 a/b/g/n/ac
Bluetooth	Bluetooth 5.0
GPS	GPS/GLONASS
WWAN	Optional 4G/ LTE or 3G

Interface

Docking Connector	1 x 19-pin docking connector (Optional)
HDMI	1 x HDMI
Serial Port	1 x RS232 Serial COM Port
LAN	1 x RJ45-10/100/1000 Mbps LAN
USB	2 x USB 3.0, 2 x USB 2.0
USB Type-C	1 x USB 3.1 Type-C (Gen1) ²
Power Input	1 x Power Jack (DC Input)
Micro SD	1 x Micro SD Slot
Audio Connector	1 x Headphone Combo Jack
Service Window	Access to 1 x mini PCI-e WWAN card
Expansion Window	1 x Optional Expansion Window (Smart Card Reader/ Barcode)

Keyboard and Input

Touch	<ul style="list-style-type: none">10-point multi-touch, support Hand / Gloves, Rain Mode, and Active Pen
Button	<ul style="list-style-type: none">On-screen QWERTY keyboard7 membrane keys: 1 x power, 1 x menu, 3 x function key (Programmable function key)

Status Indicators

LED Indicators	Power, Battery, SSD, RF
----------------	-------------------------

Audio

Microphone	1 x built-in Digital Mic with Noise Cancellation
Speaker	2 x 1 watt speaker

Cameras

Web Camera	2MP webcam
Rear Camera	5MP rear camera with autofocus and LED light

Data Capture

Barcode Reader	Optional 1D/2D barcode reader ³
Smart Card Reader	Optional built-in smart card reader
	Comply with ISO7816-1.2.3 T=1 and T=Ø protocol
RFID	Optional HF RFID Reader 13.56 MHz

Certifications

Certifications	CE, FCC, IC, UL
----------------	-----------------

Security Function

Security	<ul style="list-style-type: none">Trusted Platform Module (TPM) V2.0⁴Computrace theft protection agent⁵Kensington lock slot
Mobile Device Management	SOTI Mobicontrol compatible

Mechanical and Environment

Dimension (W x L x H)	338.2 x 240 x 30 mm (13.3 x 9.4 x 1.18 inches) ⁶
Housing	Rear Magnesium Alloy Die-Casting Design
Cooling System	Fanless thermal design
Weight	2.4 Kg (Without Kickstand), 2.5 Kg (With Kickstand)
Operating Temperature	-10°C to 50°C (14°F to 122°F)
Storage Temperature	-20°C to 60°C (-4°F to 140°F)
Humidity	30% to 80% RH, non-condensing
IP Proof	IP65
Shock	MIL-STD-810G Method 516.6 Procedure I
Vibration	MIL-STD-810G Method 514.6 Procedure I
Drop	MIL-STD-810G Method 516.6, 4 ft to concrete

Power Management

Power Input	19V DC
Battery	7.4V, typ. 10280 mAh Li-Polymer Battery (2S2P) Optional Hot-Swap
Battery Operating Time	11 Hours (BAPCo TabletMark v3) ⁷
Adapter	100-240V, 50-60Hz / 19V DC

Accessories

Standard Accessories

Adapter and PowerCord	922D065W19V6
Standard Battery	98KT00A0000R
Stylus	9B000000006U
Stand with Integrated Handle	98KT00A0000U

Optional Accessories⁸

VESA Mounting Kit	98KT00A0000Q
VESA Mounting Kit 2	98KT00A00019
RAM Mounting Kit	98K000A0007Z
Shoulder Strap	9B000000007I
Battery Charger	98JT00A00001
Vehicle Charger	9226065W19V0
Desk Docking	98DT00A0000Y

Drawing⁹

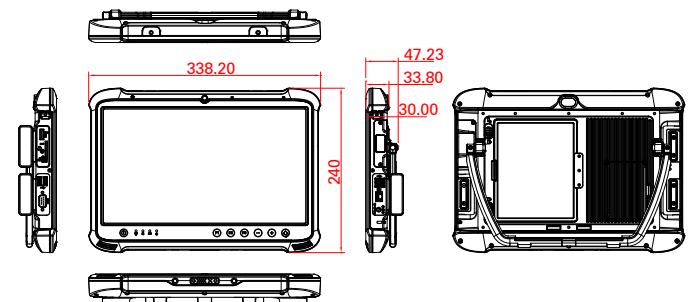

Caution

Do Not Expose the Battery Pack to Excessive Heat, or Extreme Heat (Near Fire, in Direct Sunlight for example)
Do not expose bare skin to this product when handling this unit in extreme hot or cold environments

- Total usable memory will be less depending upon actual system configuration.
- Barcode and smart card readers are mutually exclusive options.
- The USB Type-C connector follows USB 3.0 standard, which does not support Alternate Mode (ALT) or USB Power Delivery (USB-PD).
- TPM 2.0 available upon request.
- Computrace theft protection and SOTI are available upon request.
- Length measurements do not include protrusions. Weight varies with options.
- Measured at dimming LCD brightness. Varies depending on the usage conditions, or when an external device is attached.
- Accessories and Integrated Options may vary depending on your configuration.
- This is a simplified drawing and some components are not marked in detail.