

Battery for M101B/H/BT/M8

BS101

Product Features:

- Compatible with M101B, M101H, M101M8, and M101BT
- Easy installation



Mechanical Drawing

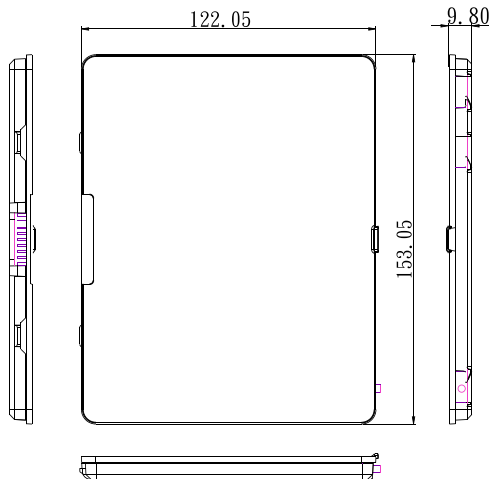

Dimensions	153 x 122 x 9.8 mm
Weight	276 g
Color	Pantone# 8403C

Installation Procedure

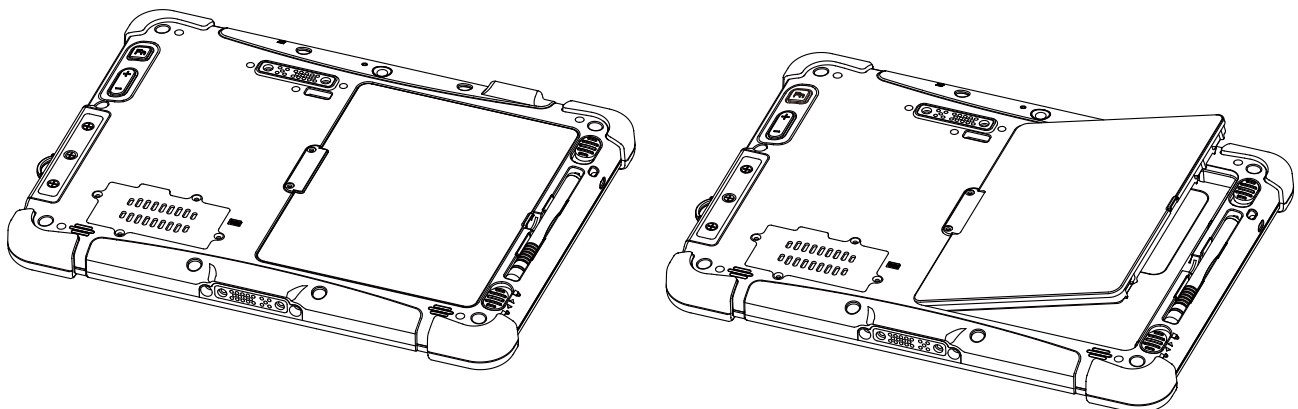

Specification

Voltage / Capacity	7.4V / typ. 5140 mAh
Composition	2S1P Li-Polymer Re-chargeable Battery
Operating Temperature	Standard Charging: 0~45°C Standard Discharging : -20~60°C
Life Cycle	≥ 300
Certification	UL2054, IEC62133, UN38.3