

# Product Catalog 2016

## IP65/IP68 Industrial Silicone Rubber Keyboard



# TABLE OF CONTENTS

TABLE OF CONTENTS .....	2
IP65/IP68 INDUSTRIAL SILICONE RUBBER KEYBOARD.....	4
PRI-KYB-M222-FNK-OEM-ML .....	6
PRI-KYB-M270-FNK-IL-MDT .....	7
PRI-KYB-M270-FNK-IL-OEM .....	8
PRI-KYB-M270-FNK-OEM-BLT-IL.....	9
PRI-KYB-M270-FNK-OEM-BLT-ML .....	10
PRI-KYB-M270-HP-BLT-IL .....	11
PRI-KYB-M275-OTBM-FNK-IL-MDT.....	12
PRI-KYB-M275RTP-FNK-BLT-IL-MDT .....	13
PRI-KYB-M275RTP-FNK-IL-FDT .....	14
PRI-KYB-M275RTP-FNK-BLT-IL-FDT .....	15
PRI-KYB-M275RTP-FNK-ML-FDT .....	16
PRI-KYB-M275RTP-FNK-BLT-ML-FDT .....	17
PRI-KYB-M275RTP-FNK-MDT-AL-IL.....	18
PRI-KYB-M275RTP-FNK-IL-OEM.....	19
PRI-KYB-M275RTP-FNK-BLT-IL-OEM .....	20
PRI-KYB-M275RTP-FNK-ML-MDT .....	21
PRI-KYB-M275RTP-FNK-WF-IL-MDT .....	22
PRI-KYB-M275RTP-FNK-BLT-ML-OEM .....	23
PRI-KYB-M275RTP-FNK-SLS-ML .....	24
PRI-KYB-M275RTP-FNK-SLS-IL .....	25
PRI-KYB-M275RTP-FNK-BLT-SLS-IL.....	26
PRI-KYB-M275RTP-FNK-MDT-AL-BLT-ML .....	27
PRI-KYB-M275RTP-FNK-IL-MDT .....	28
PRI-KYB-M275RTP-FNK-AL-ML-MDT .....	29
PRI-KYB-M275RTP-FNK-BLT-AL-IL-MDT .....	30
PRI-KYB-M276NKP-BLT-ML .....	31
PRI-KYB-M276RTP-FNK-BLT-ML-OEM .....	32
PRI-KYB-M276RTP-FNK-BLT-ML-FDT .....	33
PRI-KYB-M300NKP-FNK-IL .....	34
PRI-KYB-M368-OTBM-FNK-MDT .....	35
PRI-KYB-M368-OTBM-FNK-BLT-MDT .....	36
PRI-KYB-M375NKP-FNK-MDT .....	37
PRI-KYB-M367NKP-FNK-IL-OEM .....	38
PRI-KYB-M376NKP-FNK-FM-SLS-IL-MDT .....	39
PRI-KYB-M376NKP-FNK-SLS-IL-MDT .....	40
PRI-KYB-M375NKP-FNK-BLT-MDT .....	41
PRI-KYB-M376NKP-FNK-AL-MDT .....	42
PRI-KYB-M390NKP-FNK-BLT-MDT .....	43
PRI-KYB-M390NKP-FNK-MDT .....	44
PRI-KYB-M390RTP-NKP-FNK-BLT-MDT .....	45
PRI-KYB-M396RTP-NKP-FNK-BLT-MDT .....	46
PRI-KYB-M396-OTBM-NKP-FNK-BLT-MDT .....	47
PRI-KYB-M399NKP-FNK-MDT .....	48
PRI-KYB-M379-OTBM-NKP-FNK-OEM.....	49

PRI-KYB-M379-OTBM-NKP-FNK-IL .....	50
PRI-KYB-M379RTP-NKP-FNK-OEM .....	51
PRI-KYB-M379RTP-NKP-FNK.....	52
PRI-KYB-M379RTP-NKP-FNK-BLT-IL-OEM.....	53
PRI-KYB-M379RTP-NKP-FNK-BLT-ML-OEM.....	54
PRI-KYB-M379-OTBM-NKP-FNK-BLT-IL-OEM .....	55
PRI-KYB-M379-OTBM-NKP-FNK-BLT-IL.....	56
PRI-KYB-M379-OTBM-NKP-FNK-SLS-IL .....	57
PRI-KYB-M379-OTBM-NKP-FNK-BLT-SLS-IL .....	58
PRI-KYB-M379RTP-NKP-FNK-BLT-IL .....	59
PRI-KYB-M379RTP-NKP-FNK-SLS-IL .....	60
PRI-KYB-M379RTP-NKP-FNK-BLT-SLS-IL .....	61
PRI-KYB-M379RTP-NKP-FNK-BLT-ML .....	62
PRI-KYB-M390RTP-NKP-FNK-MDT.....	63
PRI-KYB-M396RTP-NKP-FNK-MDT.....	64
PRI-KYB-M396-OTBM-NKP-FNK-MDT .....	65
PRI-KYB-M399NKP-FNK .....	66
PRI-KYB-M399NKP-FNK-BLT .....	67
PRI-KYB-M399NKP-FNK-MDT-BLT .....	68
PRI-KYB-M399RTP-NKP-FNK.....	69
PRI-KYB-M399RTP-NKP-FNK-BLT .....	70
PRI-KYB-M399RTP-NKP-FNK-MDT-BLT .....	71
PRI-KYB-M399RTP-NKP-FNK-MDT.....	72
PRI-KYB-M62NKP-AC .....	73
PRI-KYB-M68NKP-AC .....	74

# IP65/IP68 INDUSTRIAL SILICONE RUBBER KEYBOARD

## MAIN FEATURE

- keyboard with NVIS-compliant red adjustable backlighting optional, while NVIS backlighting makes this keyboard ideal for aviation or vehicle applications where night vision goggles are necessary.
- Keyboard provides full-size versatility in a rugged, compact design, rugged construction for reliable functionality
- The keyboard lacks the crevices found between the keys of a regular keyboard, which is protected against dust, dirt, grease and corrosive liquids to NEMA 4X, which means it can withstand directed hose water, disinfectants, environmental contaminants and heavy industrial use.
- Special dura-coating for excellent mechanical and chemical resistance
- Clean key
  - Prevents data from being sent while the keyboard is wiped down, allowing user to clean at any interval with minimal downtime
  - User is notified of 'lock down mode' by brightly lit CLEAN KEY
- With firm tactile key feel, 1.5mm key travel.
- Integrated numeric keypad.
- Optical IP68 mouse available
- Ease of customizing with multiple languages, to accommodate foreign or custom variants.
- PS/2, USB connection cables that plug directly into computer like keyboard operations.

## MECHANICAL DATA

- Key top style: Protuberant rectangular keys with tactile feeling.
- Touchpad cover: Composite
- More than Lifetime 10 million strokes
- Mutual Capacitance sensing
- X/Y position sensing resolution: 40 counts/mm
- X/Y position reporting: Relative
- Output (self-detectable depending on cable): PS2 or USB
- Tracking speed: Maximum 1,016 m/sec
- Power supply voltage: 5 VDC  $\pm$ 0.25V
- Current rating (active mode): 17 mA
- Switch life: more than 10 million of operations.
- Cable Length: 2.5m

## ELECTRICAL DATA

- Supply Voltage: +5V DC +/-5%
- Current Rating:
  - PS2: keyboard with 210mA@5V (from keyboard port)
  - USB: 220mA@5V (from CPU port)
- EMC Standard: It is compliance with the council EMC directive 89/336/EEC EN55022: 1988+A1:2000+A2:2003 EN55024: 1988+A1: 2001+A2:2003
- Emission: EN 50081-1
- Immunity: EN 50082-1
- Lifespan > 3 years
- Switch Contact Material: Carbon-on-Gold key switch technology with gold PCB.
- Interface: PS2, USB available.
- **OS: Windows95/98/NT/ME/2000/2003/XP/Vista/WIN7, Linux, Unix, Mac OSX**



## ENVIRONMENTAL ADAPTABILITY

- Operating temperature: -30°C to +65°C
- Storage temperature: -40°C to +65°C
- Humidity: 100%
- Atmospheric pressure: 60-106Kpa
- Shock: 3x11 ms pulses of 50g on each of 3 axes
- Vibration: POWER SPECTRAL DENSITY: 0.04g/Hz, FREQUENCY RANGE: 20Hz - 2kHz, DURATION OF TEST PER AXIS: 3 hours
- Flammability  
PRINTED CIRCUIT BOARD: 94 VO  
SILICONE OVERLAY: 94 HB  
INTERFACE CABLE: 94 V

## RELIABILITY

- **RoHS Compliant, CE and FCC,ESD**
- **Protection Level: IP68, NEMA 6P**
- Key Lifespan >10 million actuations
- MTBF >50000H
- MTTR <30min



## PRI-KYB-M270-FNK-IL-MDT

**DESCRIPTION:** 83 keys IP68 dynamic sealed & ruggedized industrial silicone rubber Industrial keyboard, 12 function keys and industrial PCB with carbon-on-gold key switch technology with long stroke (1.50mm) with extremely good tactile feeling for fast and accurate data input without any noise, with durable coating & antimicrobial keyboard surface withstand to most chemicals and liquids under harsh environment, Clean key for easy cleaning via lock/disable whole keyboard without needing to take keyboard from PC, stand alone desk top version with sealed aluminum metal housing with sand blasting & oxygenation surface treatment, adjustable industrial backlight optional. Military level optional.

- **Number of Keys: 83**

- **Clean key**

-Prevents data from being sent while the keyboard is wiped down, allowing user to clean at any interval with minimal downtime

-User is notified of 'lock down mode' by brightly lit CLEAN KEY

- **G.W.:** 1.20 kgs



Product Name		IP Rate	
PRI-KYB-M270-FNK-IL-MD T	Keyboard; Function keys; Desk top keyboard	PS/2;USB	IP68 Dynamic
Other language versions/interfaces/configuration available on request			

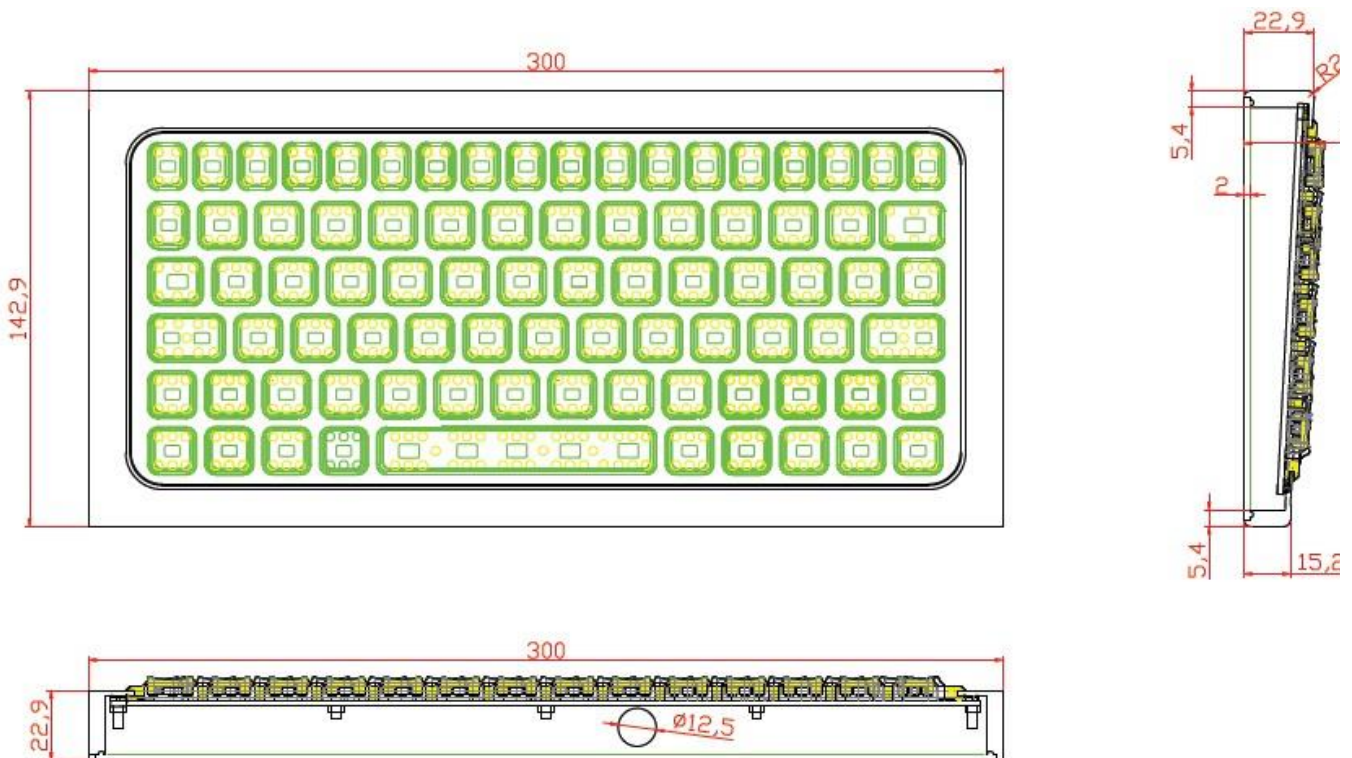

## PRI-KYB-M270-FNK-IL-OEM

**DESCRIPTION:** 83 keys IP65 dynamic sealed & ruggedized industrial silicone rubber Hygienic keyboard with industrial PCB included, 12 function keys and industrial PCB with carbon-on-gold key switch technology with long stroke (1.50mm) with extremely good tactile feeling for fast and accurate data input without any noise, with durable coating & anti-microbial keyboard surface withstand to most chemicals and liquids under harsh environment, Clean key for easy cleaning via lock/disable whole keyboard without needing to take keyboard from PC, panel mounted version, adjustable industrial backlight optional. Military level optional.

- **Number of Keys: 83**

- **Clean key**

-Prevents data from being sent while the keyboard is wiped down, allowing user to clean at any interval with minimal downtime

-User is notified of 'lock down mode' by brightly lit CLEAN KEY

- **G.W.:** 0.80 kgs

- **Dimensions:** 304.40mm x 195.8mm x 47.3(22.3)  
(L x W x H)



Product Name			IP Rate
PRI-KYB-M270-FNK-IL-OE M	Keyboard; Function keys; Front panel mounting solution	PS2/USB	IP65 Dynamic
Other language versions/interfaces/configuration available on request			

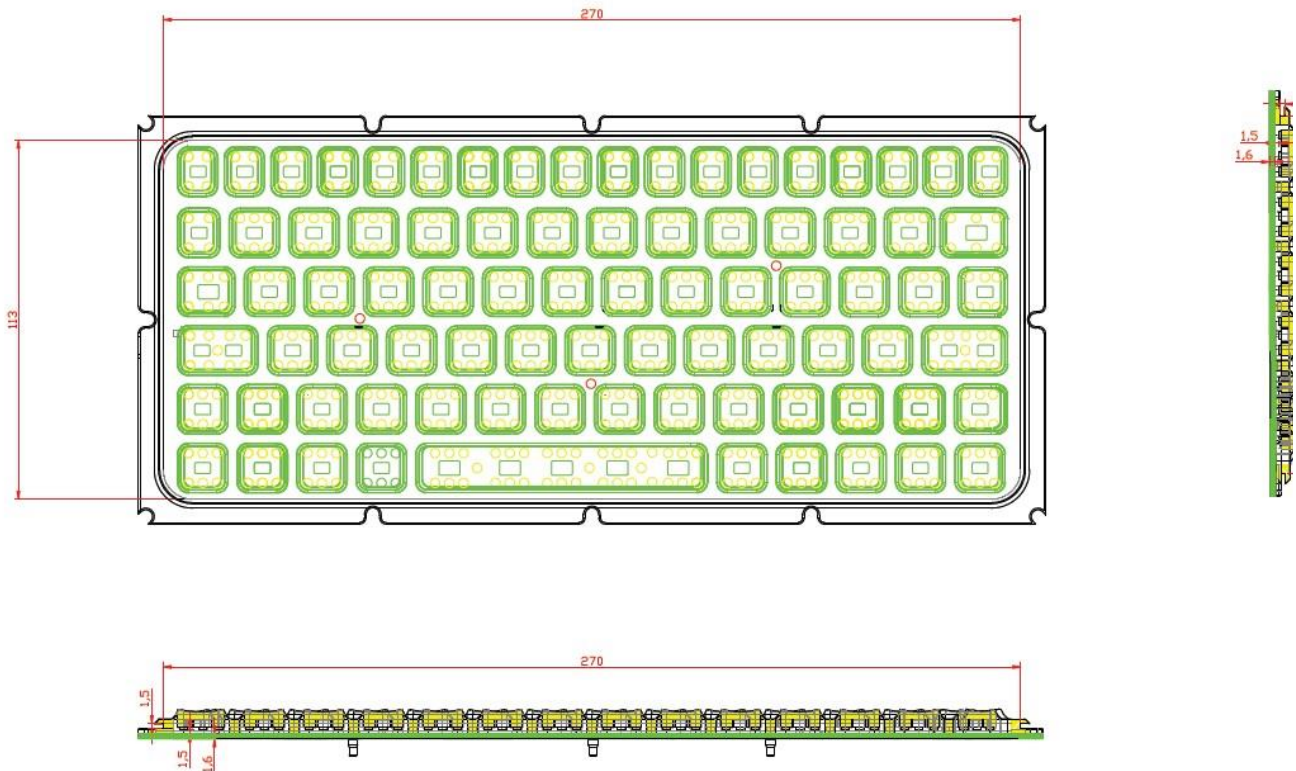



## PRI-KYB-M270-FNK-OEM-BLT-IL

**DESCRIPTION:** 83 keys IP65 dynamic sealed & ruggedized silicone rubber industrial keyboard with industrial PCB included, 12 function keys on top line for easy operation, industrial PCB with carbon-on-gold key switch technology with long stroke (1.50mm) with extremely good tactile feeling for fast and accurate data input without any noise, with durable coating & anti-microbial keyboard surface withstand to most chemicals and liquids under harsh environment, FN + Clean combination key for easy cleaning via lock/disable whole keyboard without needing to take away the keyboard from PC, panel mounted version, adjustable industrial backlight included, Industrial Level.

**DIMENSIONS :** 270.0mm x 113.0mm(L x W )

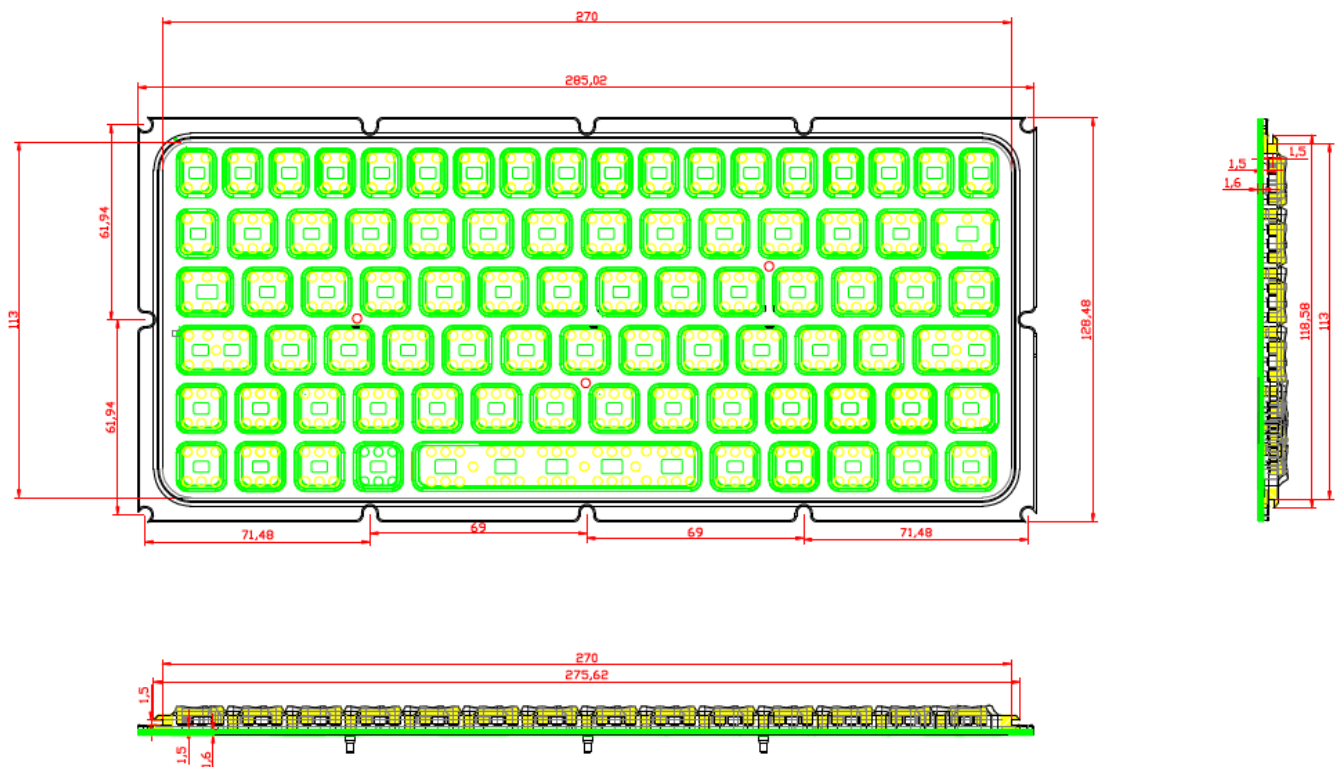

## PRI-KYB-M270-FNK-OEM-BLT-ML

**DESCRIPTION:** 83 keys IP65 dynamic sealed & ruggedized silicone rubber military keyboard with military electronics PCB included, 12 function keys on top line for easy operation, military PCB with carbon-on-gold key switch technology with long stroke (1.50mm) with extremely good tactile feeling for fast and accurate data input without any noise, with durable coating & anti-microbial keyboard surface withstand to most chemicals and liquids under harsh environment, FN + Clean combination key for easy cleaning via lock/disable whole keyboard without needing to take away the keyboard from PC, panel mounted version, adjustable backlight included, Military Level.

**DIMENSIONS :** 270.0mm x 113.0mm(L x W )

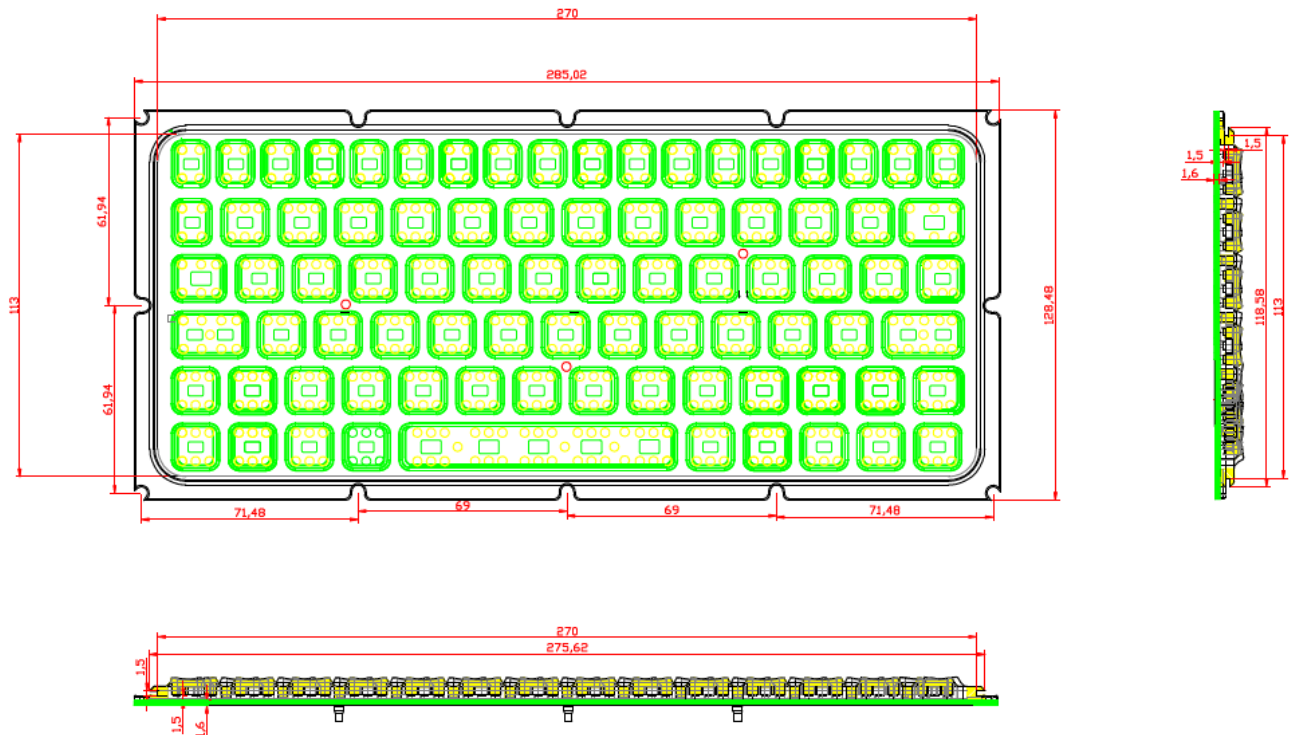

## PRI-KYB-M270-HP-BLT-IL

**DESCRIPTION:** 42 keys IP65 dynamic sealed & ruggedized silicone rubber industrial keyboard with an integrated all sealed Hula pointing device, industrial PCB with carbon-on-gold key switch technology with long stroke (1.50mm) with extremely good tactile feeling for fast and accurate data input without any noise, with durable coating & anti-microbial keyboard surface withstand to most chemicals and liquids under harsh environment, panel mounted version, adjustable backlight included, Industrial level.

**DIMENSIONS :** 270.0mm x 113.0mm(L x W )

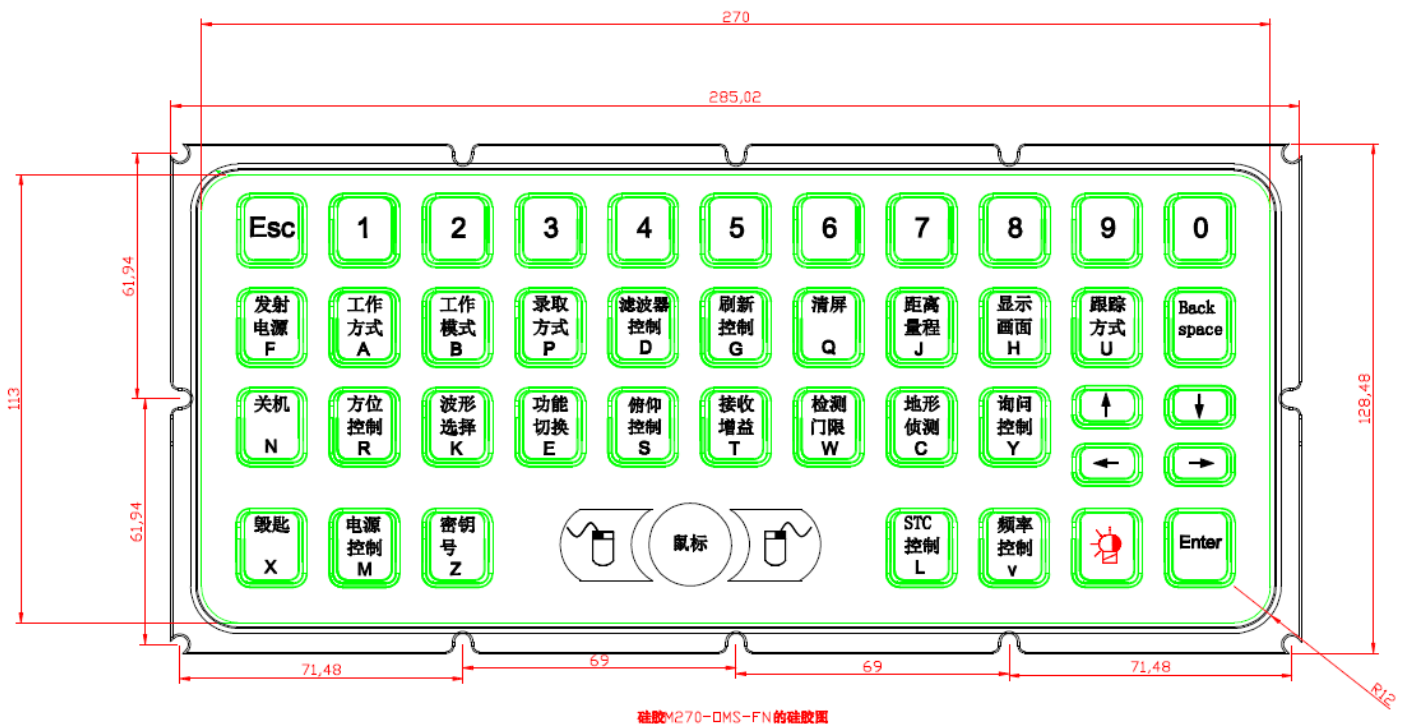



## PRI-KYB-M275-OTBM-FNK-IL-MDT

**DESCRIPTION:** 92 keys IP68 dynamic sealed & ruggedized silicone rubber industrial keyboard with full keyboard functionalities with IP68 dynamic washable 16.0mm optical trackball module with 800 DPI for fast and accurate cursor position, 12 FN keys (F1, F2...F11, F12) are on the top line for easy operation, with industrial PCB with carbon-on-gold key switch technology with long stroke (1.50mm) with extremely good tactile feeling for fast and accurate data input without any noise, with durable coating & antimicrobial keyboard surface withstand to most chemicals and liquids under harsh environment, CLEAN key for easy cleaning, adjustable industrial backlight optional. Mountable desk top version with robust poly carbonate case, military level. Industrial level optional.



- **Number of Keys: 92**
- **Clean key**
  - Prevents data from being sent while the keyboard is wiped down, allowing user to clean at any interval with minimal downtime
  - User is notified of 'lock down mode' by brightly lit CLEAN KEY
- **G.W.:** 1.20 kgs
- **Dimensions:** 304.40mm x 195.8mm x 47.3(22.3) (L x W x H)

Product Name		IP Rate
PRI-KYB-M275-OTBM-FNK-IL-MDT	Keyboard; Trackball; Function keys; Desk top keyboard	PS/2;USB IP68 Dynamic
Other language versions/interfaces/configuration available on request		

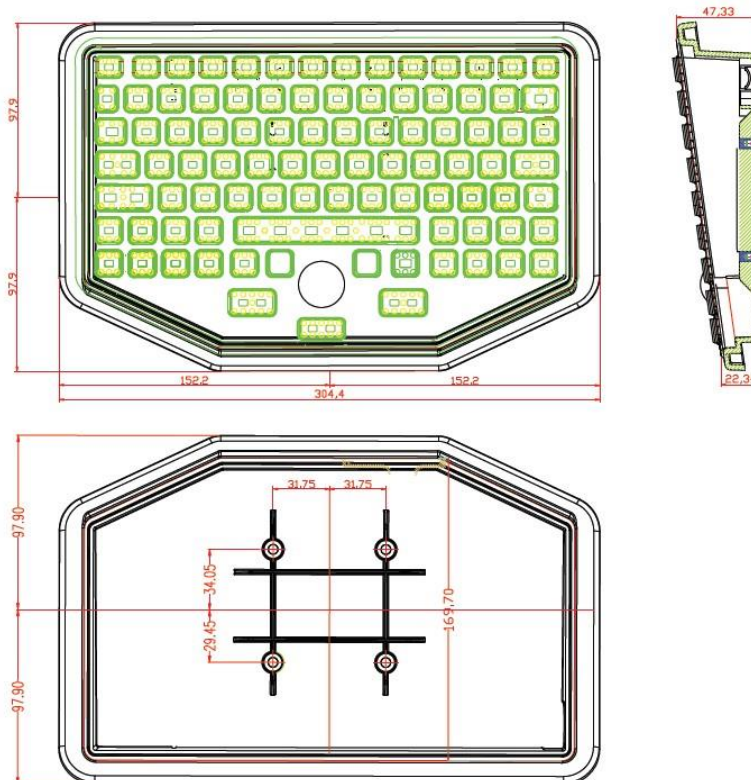



## PRI-KYB-M275RTP-FNK-BLT-IL-MDT

**DESCRIPTION:** 89 keys IP68 dynamic sealed & ruggedized silicone rubber industrial keyboard with full keyboard functionalities with sealed & ruggedized tough touchpad, 12 FN keys are on the top line for easy operation, with industrial PCB with carbon-on-gold key switch technology with long stroke (1.50mm) with extremely good tactile feeling for fast and accurate data input without any noise, with durable coating & antimicrobial keyboard surface withstand to most chemicals and liquids under harsh environment, CLEAN key for easy cleaning via lock/disable the entire keyboard without needing to take the keyboard from PC, adjustable industrial backlight optional, wired keyboard. Mountable desk top version with robust poly carbonate case, adjustable backlight included, industrial level. Military level optional.



- **Number of Keys: 89**
- **Clean key**
  - Prevents data from being sent while the keyboard is wiped down, allowing user to clean at any interval with minimal downtime
  - User is notified of 'lock down mode' by brightly lit CLEAN KEY
- **G.W.:** 1.00 kgs
- **Dimensions:** 304.40mm x 195.8mm x 47.3(22.3) (L x W x H)

Product Name			IP Rate
PRI-KYB-M275RTP-FNK-BLT-I L-MDT	Keyboard; Touchpad; Function keys; Desk top keyboard	PS/2;USB	IP68 Dynamic
Other language versions/interfaces/configuration available on request			

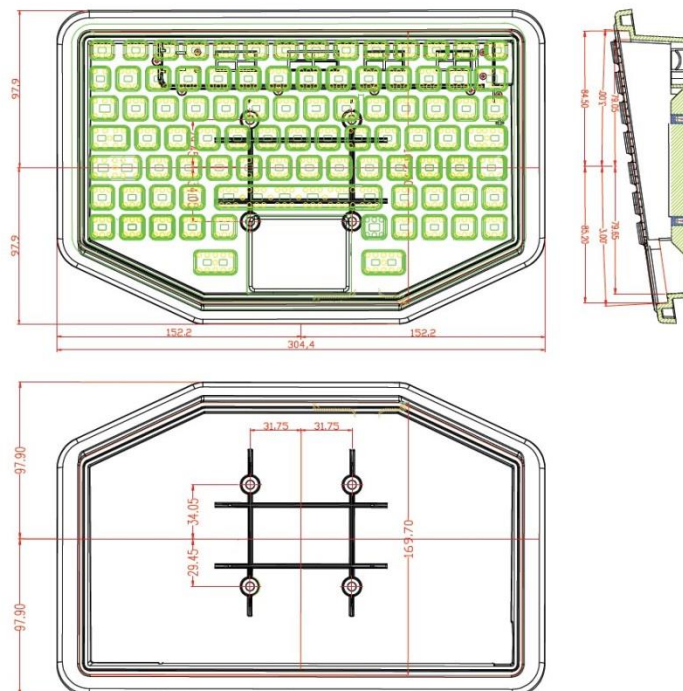

## PRI-KYB-M275RTP-FNK-IL-FDT

**DESCRIPTION:** 89 keys IP68 dynamic water proof sealed & ruggedized silicone rubber industrial keyboard with full keyboard functionalities with sealed & ruggedized tough touchpad for fast and accurate cursor position, 12 FN keys (F1, F2...F11,F12) are on the top line for easy operation, with industrial PCB with carbon-on-gold key switch technology with long stroke (1.50mm) with extremely good tactile feeling for fast and accurate data input without any noise, with durable coating & antimicrobial keyboard surface withstand to most chemicals and liquids under harsh environment, FN + CLEAN key for easy cleaning via lock/disable the entire keyboard without needing to take the keyboard from PC, adjustable industrial backlight optional, VESA mountable super flat desk top version with robust ABS polycarbonate case, industrial level. military level optional.

**Dimensions:** 296.16mm x 192mm x 21.55mm



- **Number of Keys: 89**
- **Clean key**
  - Prevents data from being sent while the keyboard is wiped down, allowing user to clean at any interval with minimal downtime
  - User is notified of 'lock down mode' by brightly lit CLEAN KEY
- **G.W.:** 1.00 kgs
- **Dimensions:** 296.16mm x 192mm x 21.55
- (L x W x H)

Product Name			IP Rate
PRI-KYB-M275RTP-FNK-IL-FDT	Keyboard; Touchpad; Function keys; Desk top keyboard	PS/2;USB	IP68 Dynamic
Other language versions/interfaces/configuration available on request			

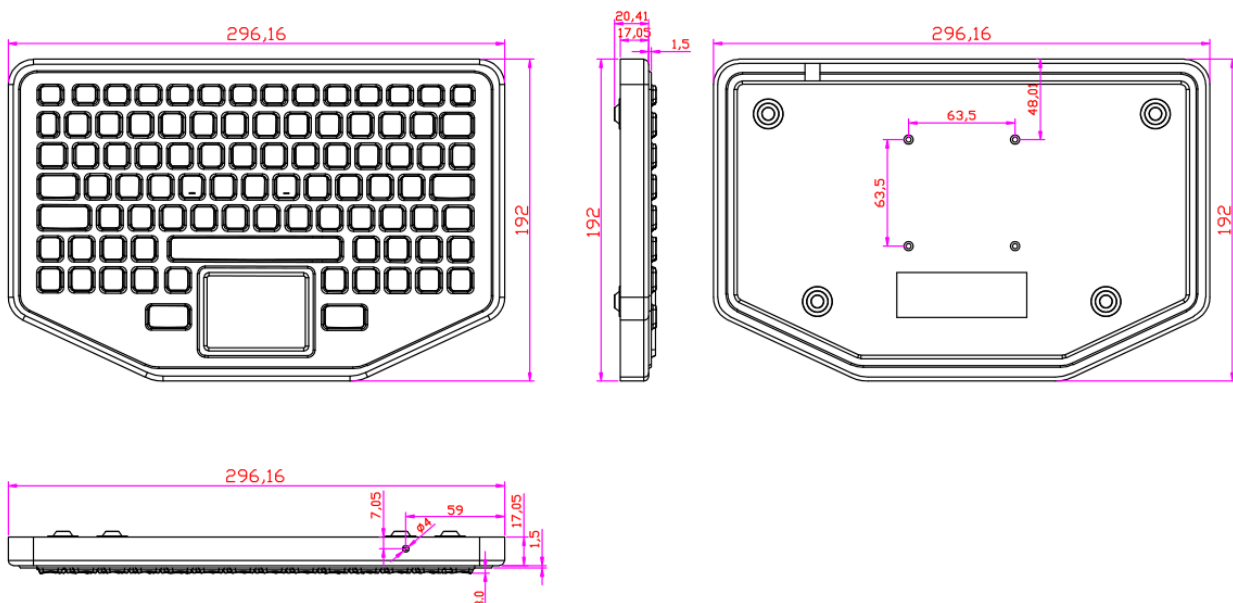

## PRI-KYB-M275RTP-FNK-BLT-IL-FDT

**DESCRIPTION:** 89 keys IP68 dynamic water proof sealed & ruggedized silicone rubber industrial keyboard with full keyboard functionalities with sealed & ruggedized tough touchpad for fast and accurate cursor position, 12 FN keys (F1, F2...F11,F12) are on the top line for easy operation, with industrial PCB with carbon-on-gold key switch technology with long stroke (1.50mm) with extremely good tactile feeling for fast and accurate data input without any noise, with durable coating & antimicrobial keyboard surface withstand to most chemicals and liquids under harsh environment, FN + CLEAN key for easy cleaning via lock/disable the entire keyboard without needing to take the keyboard from PC, adjustable industrial backlight included, VESA mountable super flat desk top version with robust ABS polycarbonate case, industrial level. military level optional.

**Dimensions:** 296.16mm x 192mm x 21.55mm



- **Number of Keys: 89**
- **Clean key**
  - Prevents data from being sent while the keyboard is wiped down, allowing user to clean at any interval with minimal downtime
  - User is notified of 'lock down mode' by brightly lit CLEAN KEY
- **G.W.:** 1.00 kgs
- **Dimensions:** 296.16mm x 192mm x 21.55
- (L x W x H)

Product Name		IP Rate	
PRI-KYB-M275RTP-FNK-BLT-I L-FDT	Keyboard; Touchpad; Function keys; Desk top keyboard	PS/2;USB	IP68 Dynamic
Other language versions/interfaces/configuration available on request			

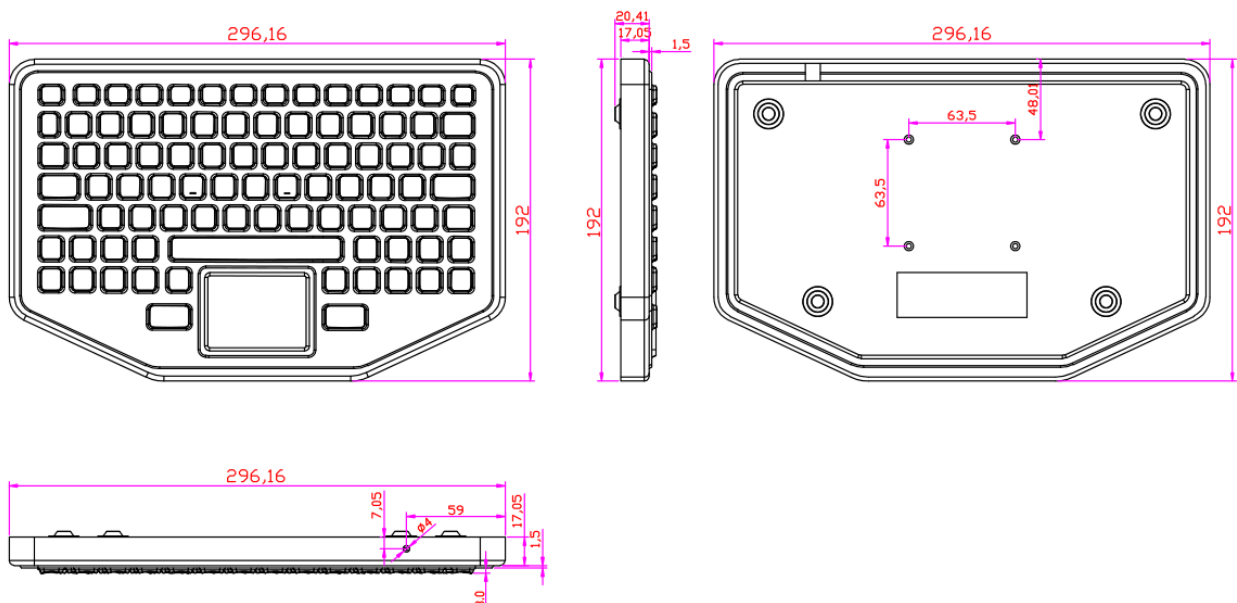

## PRI-KYB-M275RTP-FNK-ML-FDT

**DESCRIPTION:** 89 keys IP68 dynamic water proof sealed & ruggedized silicone rubber industrial keyboard with full keyboard functionalities with sealed & ruggedized tough touchpad for fast and accurate cursor position, 12 FN keys (F1, F2...F11,F12) are on the top line for easy operation, with industrial PCB with carbon-on-gold key switch technology with long stroke (1.50mm) with extremely good tactile feeling for fast and accurate data input without any noise, with durable coating & antimicrobial keyboard surface withstand to most chemicals and liquids under harsh environment, FN + CLEAN key for easy cleaning via lock/disable the entire keyboard without needing to take the keyboard from PC, adjustable industrial backlight optional, VESA mountable super flat desk top version with robust ABS polycarbonate case, military level.

**Dimensions:** 296.16mm x 192mm x 17.55mm



- **Number of Keys: 89**
- **Clean key**
  - Prevents data from being sent while the keyboard is wiped down, allowing user to clean at any interval with minimal downtime
  - User is notified of 'lock down mode' by brightly lit CLEAN KEY
- **G.W.:** 1.00 kgs
- **Dimensions:** 296.16mm x 192mm x 17.55 (L x W x H)

Product Name			IP Rate
PRI-KYB-M275RTP-FNK-M L-FDT	Keyboard; Touchpad; Function keys; Desk top keyboard	PS/2;USB	IP68 Dynamic
Other language versions/interfaces/configuration available on request			

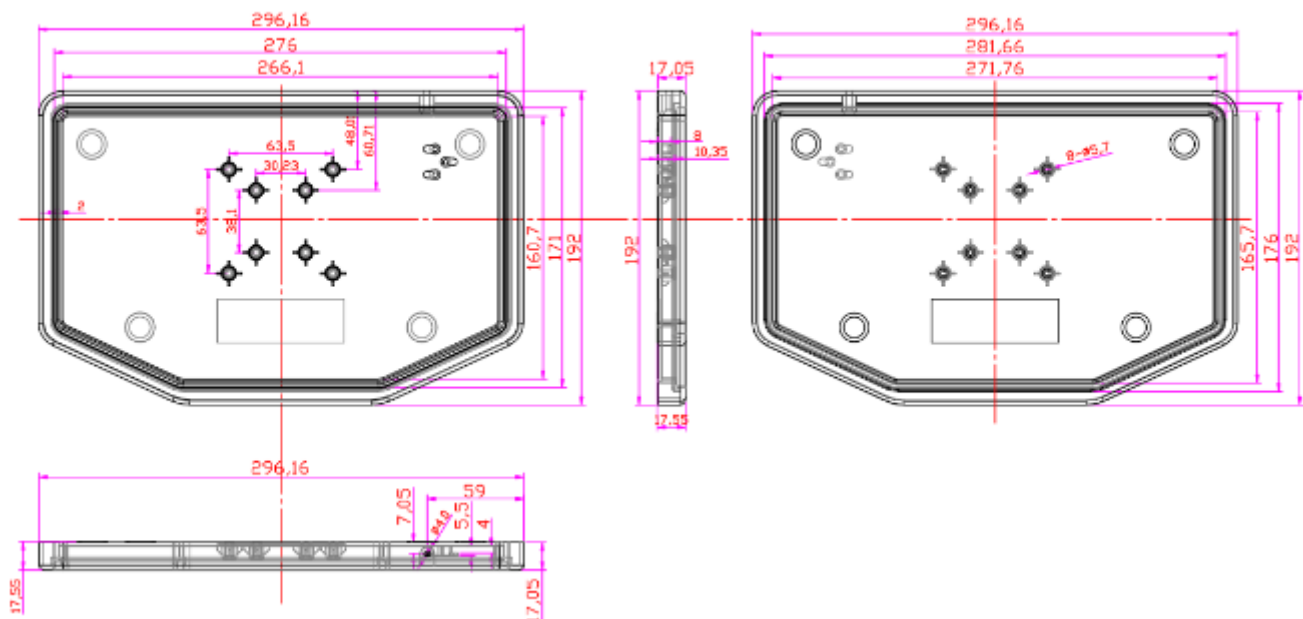



## PRI-KYB-M275RTP-FNK-BLT-ML-FDT

**DESCRIPTION:** 89 keys IP68 dynamic water proof sealed & ruggedized silicone rubber industrial keyboard with full keyboard functionalities with sealed & ruggedized tough touchpad for fast and accurate cursor position, 12 FN keys (F1, F2...F11,F12) are on the top line for easy operation, with industrial PCB with carbon-on-gold key switch technology with long stroke (1.50mm) with extremely good tactile feeling for fast and accurate data input without any noise, with durable coating & antimicrobial keyboard surface withstand to most chemicals and liquids under harsh environment, FN + CLEAN key for easy cleaning via lock/disable the entire keyboard without needing to take the keyboard from PC, adjustable industrial backlight included, VESA mountable super flat desk top version with robust ABS polycarbonate case, military level optional.

**Dimensions:** 296.16mm x 192mm x 17.55mm



- **Number of Keys: 89**
- **Clean key**
  - Prevents data from being sent while the keyboard is wiped down, allowing user to clean at any interval with minimal downtime
  - User is notified of 'lock down mode' by brightly lit CLEAN KEY
- **G.W.:** 1.00 kgs
- **Dimensions:** 296.16mm x 192mm x 17.55
- (L x W x H)

Product Name		IP Rate	
PRI-KYB-M275RTP-FNK-BLT-M L-FDT	Keyboard; Touchpad; Function keys; Desk top keyboard	PS/2;USB	IP68 Dynamic
Other language versions/interfaces/configuration available on request			

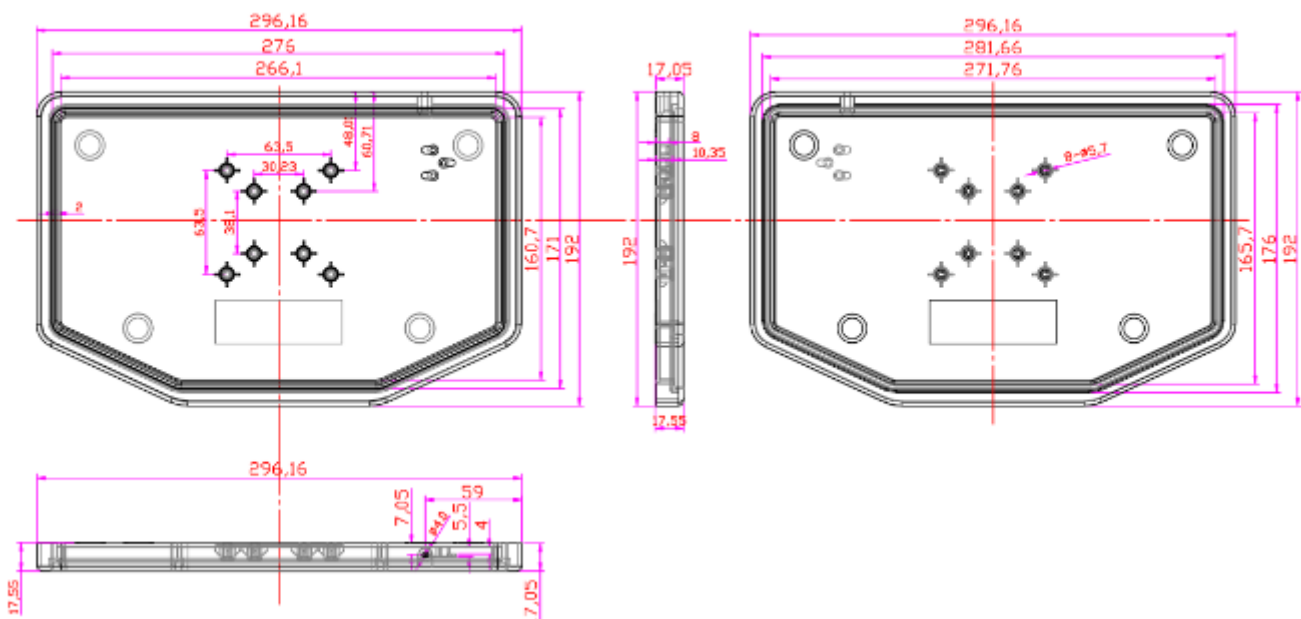

## PRI-KYB-M275RTP-FNK-MDT-AL-IL

**DESCRIPTION:** 89 keys IP68 dynamic sealed and ruggedized silicone rubber industrial keyboard with full keyboard functionalities with sealed & ruggedized tough touchpad for fast and accurate cursor position, 12 FN keys (F1, F2...F11,F12) are on the top line for easy operations, with industrial PCB with carbon-on-gold key switch technology with long stroke (1.50mm) with extremely good tactile feeling for fast and accurate data input without any noise, with durable coating & antimicrobial keyboard surface withstand to most chemicals and liquids under harsh environment, CLEAN key for easy cleaning via locking/disable the entire keyboard without needing to take the keyboard from PC, movable stand alone desk top version with IP68 dynamic washable sealed aluminum metal housing with sand blasting & oxygenation surface treatment, industrial level. Adjustable industrial backlight optional, military level optional.



- **Number of Keys: 89**

- **Clean key**

- Prevents data from being sent while the keyboard is wiped down, allowing user to clean at any interval with minimal downtime

- User is notified of 'lock down mode' by brightly lit CLEAN KEY

- **G.W.:** 2.00 kgs

- **Dimensions:** 295.00mm x 189.60mm x 18.00 mm (L x W x H)

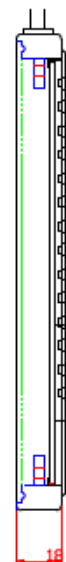
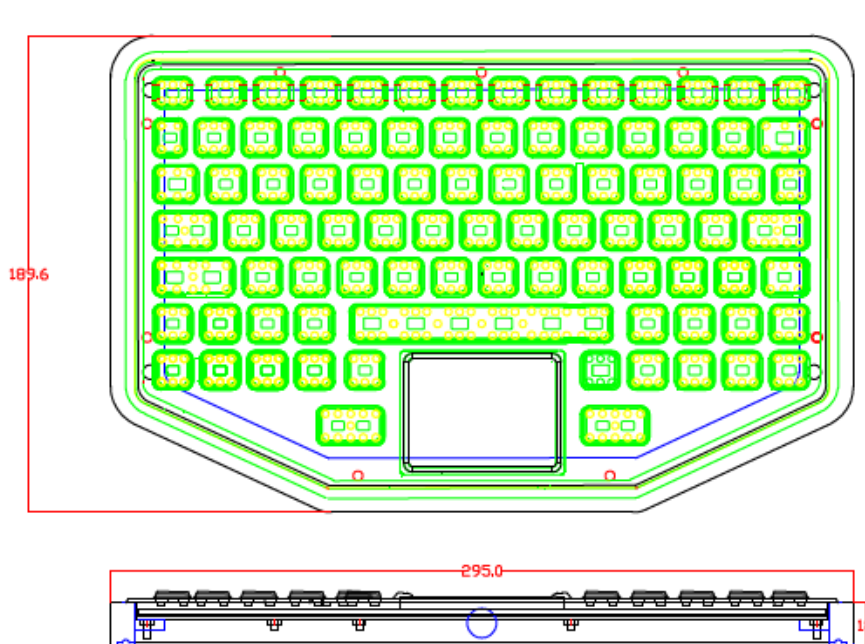

## PRI-KYB-M275RTP-FNK-IL-OEM

**DESCRIPTION:** 89 keys IP65 dynamic sealed and ruggedized silicone rubber Hygienic industrial keyboard with full keyboard top line for easy operation, with industrial PCB with carbon-on-gold key switch technology with long stroke (1.50mm) with extremely good tactile feeling for fast and accurate data input without any noise, with durable coating & antimicrobial keyboard surface withstand to most chemicals and liquids under harsh environment, FN + CLEAN key to lock/disable the keyboard for easy cleaning without needing to take away the keyboard from PC, industrial PCB sealed and ruggedized with top rubber for top panel mounting, industrial level. With adjustable backlight optional.

With optional stainless steel back plate sealed and ruggedized with top industrial silicone cover & industrial PCB for ruggedized structure and easy mounting and sealing, stainless steel housing protects the electronics controller.



- **Number of Keys:** 89
- **Clean key**
  - Prevents data from being sent while the keyboard is wiped down, allowing user to clean at any interval with minimal downtime
  - User is notified of 'lock down mode' by brightly lit CLEAN KEY
- **G.W.:** 0.80 kgs
- **Dimensions:** 275.0mm x 169.60mm (L x W )

Product Name		IP Rate
PRI-KYB-M275RTP-FNK-IL-OEM	Keyboard; Touchpad; Function keys	IP65 Dynamic
Other language versions/interfaces/configuration available on request		

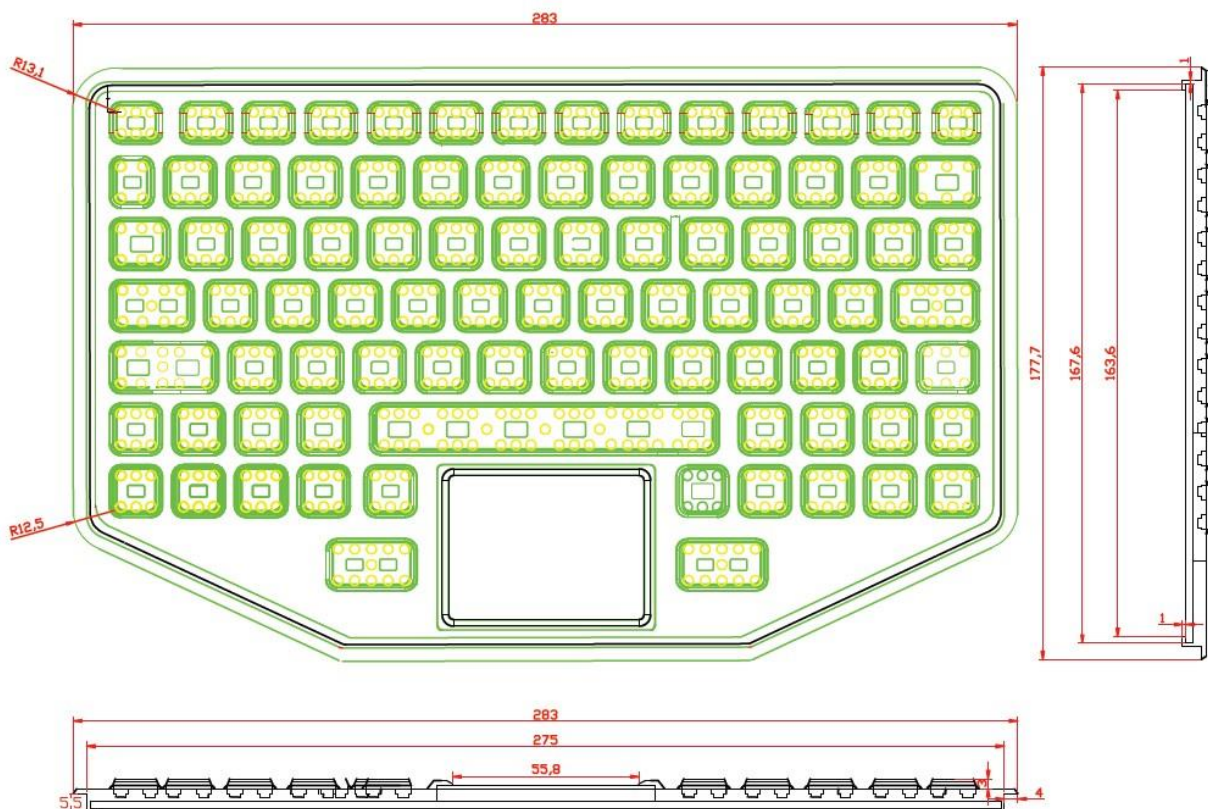



## PRI-KYB-M275RTP-FNK-BLT-IL-OEM

**DESCRIPTION:** 89 keys IP65 dynamic sealed and ruggedized silicone rubber Hygienic industrial keyboard with full keyboard functionalities with sealed & ruggedized tough touchpad for fast and accurate cursor position, 12 FN keys (F1, F2...F11, F12) are on top line for easy operation, with industrial PCB with carbon-on-gold key switch technology with long stroke (1.50mm) with extremely good tactile feeling for fast and accurate data input without any noise, with durable coating & antimicrobial keyboard surface withstand to most chemicals and liquids under harsh environment, FN + CLEAN key to lock/disable the keyboard for easy cleaning without needing to take away the keyboard from PC, industrial PCB sealed and ruggedized with top rubber for top panel mounting, industrial level with adjustable backlight included.

With optional stainless steel back plate sealed and ruggedized with top industrial silicone cover & industrial PCB for ruggedized structure and easy mounting and sealing, stainless steel housing protects the electronics controller.

**DIMENSIONS:** 275.00mm x 168.00mm (L x W )

### APPLICATIONS:

This ruggedized and compact design keyboard can be good for working in low-light areas, it is with LED backlighting. Engineered for NEMA 4X protection from dust, water and corrosive liquids. This keyboard is ideal for below wide applications:

**MEDICAL:** lab, hospital, clinic, dental, such as carts, diagnostic equipments, operation rooms, dialysis centers etc;

**MATERIAL HANDLING:** mobile keyboard, data entry, assembly line etc

**MILITARY:** Army, Navy, Air force

**INDUSTRIAL:** Industrial automation, pharmaceutical, oil and gas, food and beverage, clean or dirty manufacturing environments, warehouses

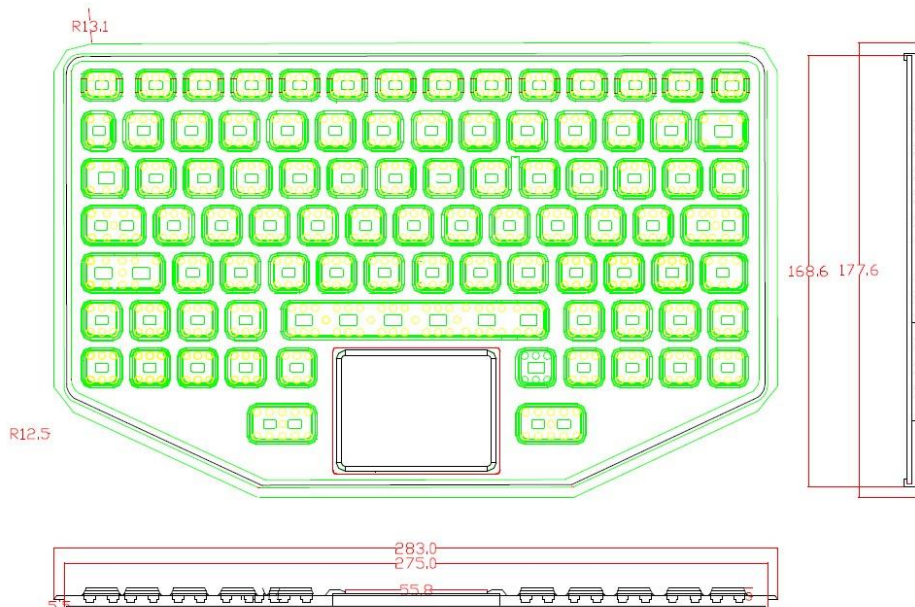



## PRI-KYB-M275RTP-FNK-ML-MDT

**DESCRIPTION:** 89 keys IP68 dynamic sealed & ruggedized silicone rubber keyboard with full keyboard functionalities with sealed & ruggedized tough touchpad, 12 FN keys are on the top line for easy operation, with gold finish PCB with carbon-on-gold key switch technology with long stroke (1.50mm) with extremely good tactile feeling for fast and accurate data input without any noise, with durable coating & antimicrobial keyboard surface withstand to most chemicals and liquids under harsh environment, CLEAN key for easy cleaning via lock/disable the entire keyboard without needing to take the keyboard from PC, wired keyboard. Mountable desk top version with robust polycarbonate case, military level. Adjustable backlight optional, Industrial level optional.

**DIMENSIONS :** 304.40mm x 195.80mm x (22.34mm-47.33mm) (L x W x H)

### APPLICATIONS:

This keyboard provides full-size versatility in a rugged, compact design with the added convenience of an integrated touchpad. For working in low-light areas, it is also available with optional LED backlighting. Engineered for NEMA 4X protection from dust, water and corrosive liquids. This keyboard is ideal for use in environments ranging from manufacturing to material handling to medical settings. The tactile keys allows for easy data entry, while its robust polycarbonate case protects it against any hazardous environment.

**MEDICAL:** lab, hospital, clinic, dental, such as carts, diagnostic equipment, operation rooms, dialysis centers etc;

**MATERIAL HANDLING:** mobile keyboard, data entry, assembly line etc

**MILITARY:** Army, Navy, Air force

**INDUSTRIAL:** Industrial automation, pharmaceutical, oil and gas, food and beverage, clean or dirty manufacturing environments, warehouses

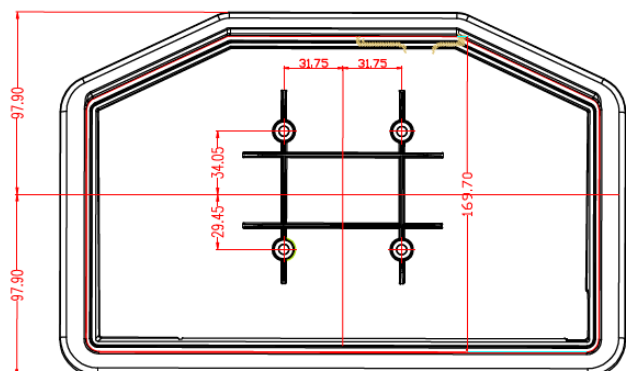
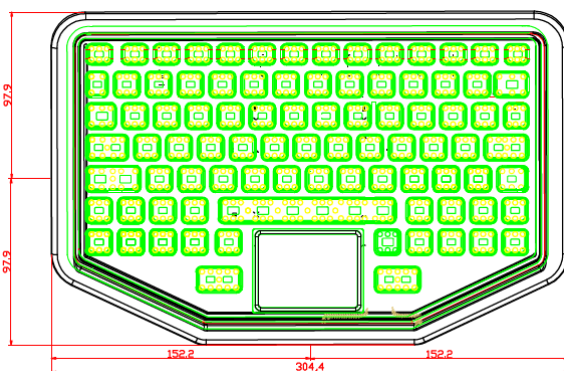

## PRI-KYB-M275RTP-FNK-WF-IL-MDT

**DESCRIPTION:** IP68 dynamic sealed & ruggedized industrial silicone rubber industrial keyboard with full keyboard functionalities with sealed & ruggedized tough touchpad, blue tooth wireless industrial keyboards, with industrial PCB with carbon-on-gold key switch technology with long stroke (1.50mm) with extremely good tactile feeling for fast and accurate data input without any noise, with durable coating & antimicrobial keyboard surface withstand to most chemicals and liquids under harsh environment, Clean key for easy cleaning, Blue-tooth wireless versions, mountable desk top version with robust poly carbonate case.

**DIMENSIONS :** 304.40mm x 195.8mm x (22.30mm-47.30mm) (L x W x H)

### APPLICATIONS:

This keyboard provides full-size versatility in a rugged, compact design with the added convenience of an integrated touchpad. For working in low-light areas, it is also available with optional LED backlighting. Engineered for NEMA 4X protection from dust, water and corrosive liquids. This keyboard is ideal for use in environments ranging from manufacturing to material handling to medical settings. Its large numeric pad allows for easy data entry, while its robust polycarbonate case protects it against any hazardous environment.

**MEDICAL:** lab, hospital, clinic, dental, such as carts, diagnostic equipments, operation rooms, dialysis centers etc;

**MATERIAL HANDLING:** mobile keyboard, data entry, assembly line etc

**MILITARY:** Army, Navy, Air force

**INDUSTRIAL:** Industrial automation, pharmaceutical, oil and gas, food and beverage, clean or dirty manufacturing environments, warehouses

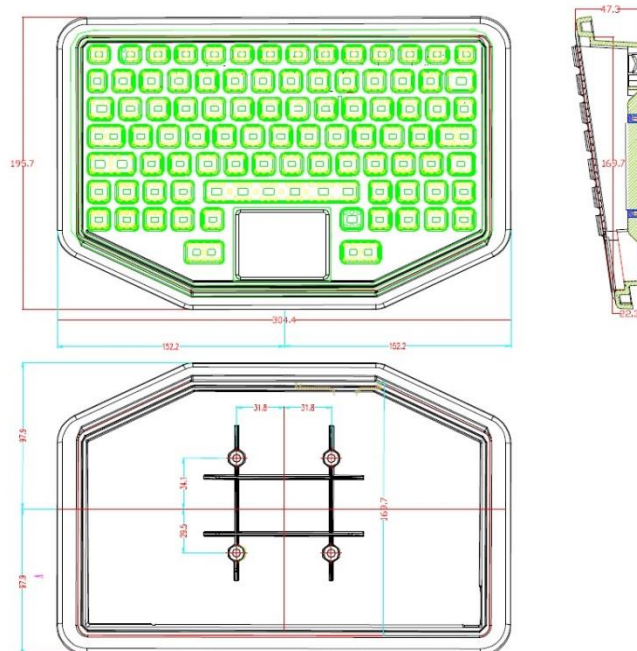

## PRI-KYB-M275RTP-FNK-BLT-ML-OEM

**DESCRIPTION:** 89 keys IP65 dynamic sealed and ruggedized silicone rubber Hygienic keyboard with full keyboard functionalities with sealed & ruggedized tough touchpad for fast and accurate cursor position, 12 FN keys (F1, F2...F11, F12) are on top line for easy operation, with gold PCB with carbon-on-gold key switch technology with long stroke (1.50mm) with extremely good tactile feeling for fast and accurate data input without any noise, with durable coating & antimicrobial keyboard surface withstand to most chemicals and liquids under harsh environment, FN + CLEAN key to lock/disable the keyboard for easy cleaning without needing to take away the keyboard from PC, gold PCB sealed and ruggedized with top rubber for top panel mounting, military level with adjustable backlight included.

With optional stainless steel back plate sealed and ruggedized with top silicone cover & gold PCB for ruggedized structure and easy mounting and sealing, stainless steel housing protects the electronics controller.

**DIMENSIONS:** 275.00mm x 168.00mm (L x W )

### APPLICATIONS:

This ruggedized and compact design keyboard can be good for working in low-light areas, it is with LED backlighting. Engineered for NEMA 4X protection from dust, water and corrosive liquids. This keyboard is ideal for below wide applications:

**MEDICAL:** lab, hospital, clinic, dental, such as carts, diagnostic equipments, operation rooms, dialysis centers etc;

**MATERIAL HANDLING:** mobile keyboard, data entry, assembly line etc

**MILITARY:** Army, Navy, Air force

**INDUSTRIAL:** Industrial automation, pharmaceutical, oil and gas, food and beverage, clean or dirty manufacturing environments, warehouses

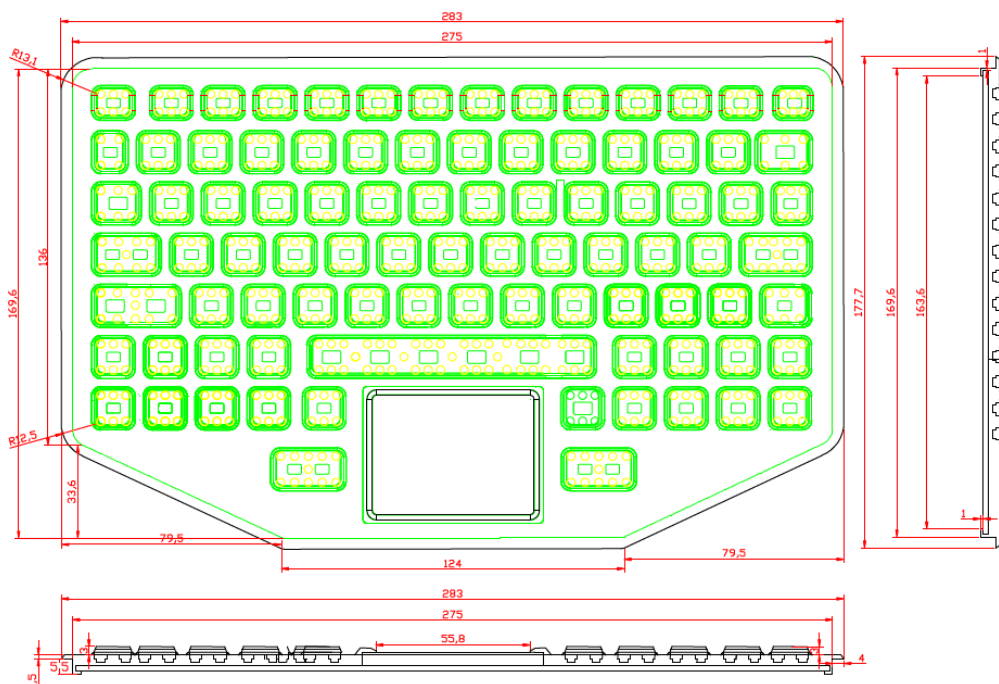

## PRI-KYB-M275RTP-FNK-SLS-ML

**DESCRIPTION:** 89 keys IP65 dynamic sealed and ruggedized silicone rubber Hygienic keyboard with full keyboard functionalities with sealed & ruggedized tough touchpad for fast and accurate cursor position, 12 FN keys (F1, F2...F11, F12) are on top line for easy operation, with gold PCB with carbon-on-gold key switch technology with long stroke (1.50mm) with extremely good tactile feeling for fast and accurate data input without any noise, with durable coating & antimicrobial keyboard surface withstand to most chemicals and liquids under harsh environment, FN + CLEAN key to lock/disable the keyboard for easy cleaning without needing to take away the keyboard from PC, gold finish PCB with stainless steel back plate sealed and ruggedized with top industrial silicone cover & industrial PCB for ruggedized structure and easy mounting and sealing, stainless steel housing protects the electronics controller, military level, with adjustable backlight optional.

**DIMENSIONS:** 275.00mm x 168.00mm (L x W )

### APPLICATIONS:

This ruggedized and compact design keyboard can be good for working in low-light areas, it is also available with optional LED backlighting. Engineered for NEMA 4X protection from dust, water and corrosive liquids. This keyboard is ideal for below wide applications:

**MEDICAL:** lab, hospital, clinic, dental, such as carts, diagnostic equipments, operation rooms, dialysis centers etc;

**MATERIAL HANDLING:** mobile keyboard, data entry, assembly line etc

**MILITARY:** Army, Navy, Air force

**INDUSTRIAL:** Industrial automation, pharmaceutical, oil and gas, food and beverage, clean or dirty manufacturing environments, warehouses

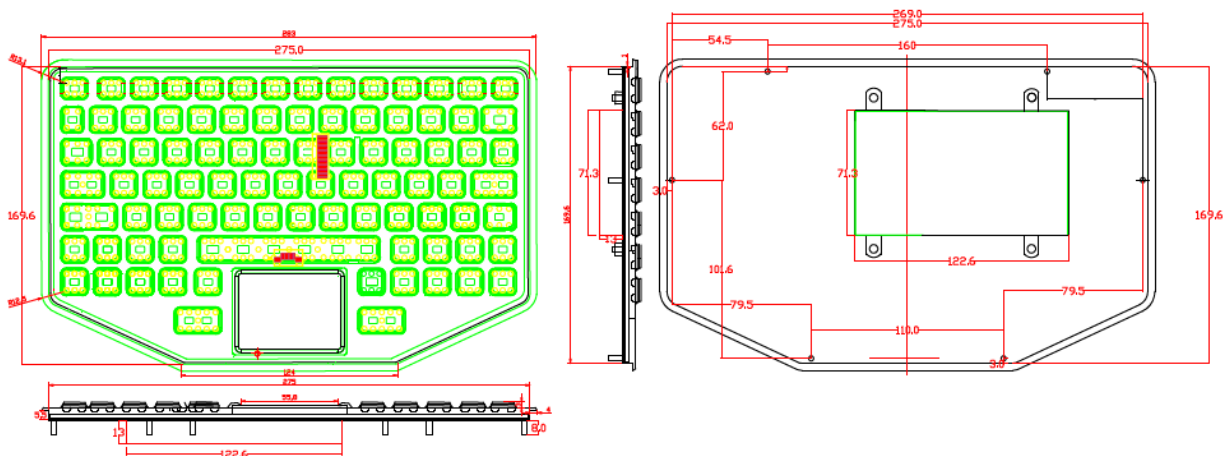



## PRI-KYB-M275RTP-FNK-SLS-IL

**DESCRIPTION:** 89 keys IP65 dynamic sealed and ruggedized silicone rubber Hygienic industrial keyboard with full keyboard functionalities with sealed & ruggedized tough touchpad for fast and accurate cursor position, 12 FN keys (F1, F2...F11, F12) are on top line for easy operation, with industrial PCB with carbon-on-gold key switch technology with long stroke (1.50mm) with extremely good tactile feeling for fast and accurate data input without any noise, with durable coating & antimicrobial keyboard surface withstand to most chemicals and liquids under harsh environment, FN + CLEAN key to lock/disable the keyboard for easy cleaning without needing to take away the keyboard from PC, industrial PCB with stainless steel back plate sealed and ruggedized with top industrial silicone cover & industrial PCB for ruggedized structure and easy mounting and sealing, stainless steel housing protects the electronics controller, industrial level with adjustable backlight optional.

**DIMENSIONS:** 275.00mm x 168.60mm (L x W )

### APPLICATIONS:

This ruggedized and compact design keyboard can be good for working in low-light areas, it is also available with optional LED backlighting. Engineered for NEMA 4X protection from dust, water and corrosive liquids. This keyboard is ideal for below wide applications:

**MEDICAL:** lab, hospital, clinic, dental, such as carts, diagnostic equipment, operation rooms, dialysis centers etc;

**MATERIAL HANDLING:** mobile keyboard, data entry, assembly line etc

**MILITARY:** Army, Navy, Air force

**INDUSTRIAL:** Industrial automation, pharmaceutical, oil and gas, food and beverage, clean or dirty manufacturing environments, warehouses

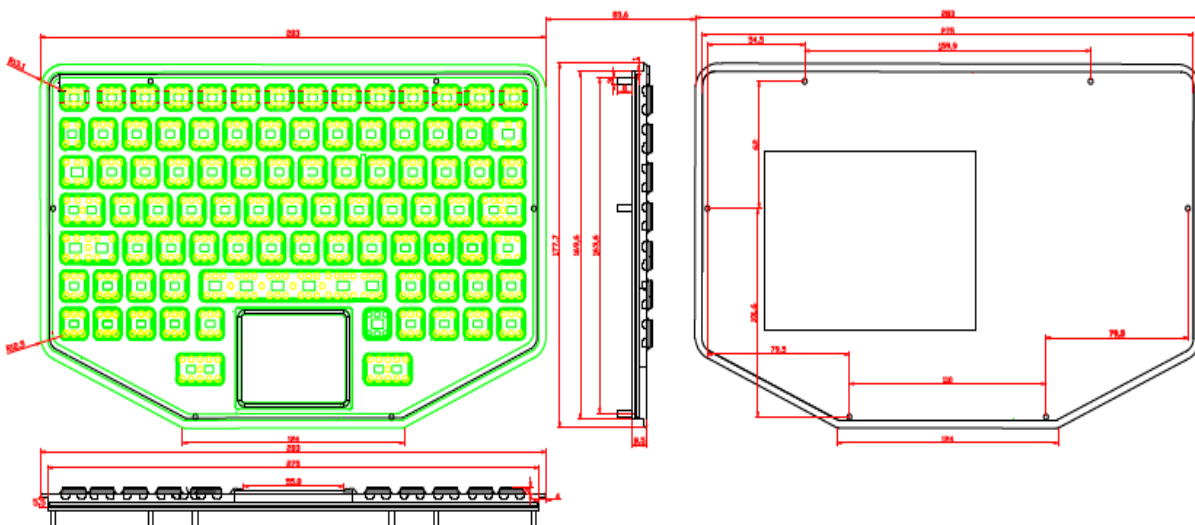

## PRI-KYB-M275RTP-FNK-BLT-SLS-IL

**DESCRIPTION:** 89 keys IP65 dynamic sealed and ruggedized silicone rubber Hygienic industrial keyboard with full keyboard functionalities with sealed & ruggedized tough touchpad for fast and accurate cursor position, 12 FN keys (F1, F2...F11, F12) are on top line for easy operation, with industrial PCB with carbon-on-gold key switch technology with long stroke (1.50mm) with extremely good tactile feeling for fast and accurate data input without any noise, with durable coating & antimicrobial keyboard surface withstand to most chemicals and liquids under harsh environment, FN + CLEAN key to lock/disable the keyboard for easy cleaning without needing to take away the keyboard from PC, industrial PCB with stainless steel back plate sealed and ruggedized with top industrial silicone cover & industrial PCB for ruggedized structure and easy mounting and sealing, stainless steel housing protects the electronics controller, industrial level with adjustable backlight included.

**DIMENSIONS:** 275.00mm x 168.00mm (L x W )

### APPLICATIONS:

This ruggedized and compact design keyboard can be good for working in low-light areas, it is also available with LED backlighting.

Engineered for NEMA 4X protection from dust, water and corrosive liquids. This keyboard is ideal for below wide applications:

**MEDICAL:** lab, hospital, clinic, dental, such as carts, diagnostic equipments, operation rooms, dialysis centers etc;

**MATERIAL HANDLING:** mobile keyboard, data entry, assembly line etc

**MILITARY:** Army, Navy, Air force

**INDUSTRIAL:** Industrial automation, pharmaceutical, oil and gas, food and beverage, clean or dirty manufacturing environments, warehouses

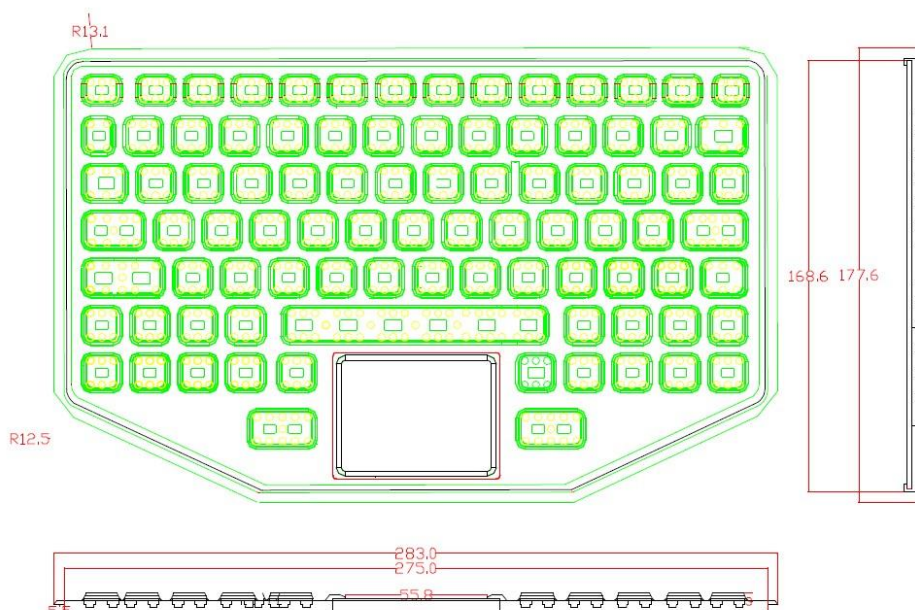

## PRI-KYB-M275RTP-FNK-MDT-AL-BLT-ML

**DESCRIPTION:** 89 keys IP68 dynamic sealed and ruggedized silicone rubber keyboard with full keyboard functionalities with sealed & ruggedized tough touchpad for fast and accurate cursor position, 12 FN keys (F1, F2...F11,F12) are on the top line for easy operations, with gold finish PCB with carbon-on-gold key switch technology with long stroke (1.50mm) with extremely good tactile feeling for fast and accurate data input without any noise, with durable coating & antimicrobial keyboard surface withstand to most chemicals and liquids under harsh environment, CLEAN key for easy cleaning via locking /disable the entire keyboard without needing to take the keyboard from PC, movable stand alone desk top version with IP68 dynamic washable sealed aluminum metal housing with sand blasting & oxygenation surface treatment, adjustable backlight included, military level. Industrial level optional.

**DIMENSIONS:** 295.40mm x 198.60mm x 18.00 mm (L x W x H)

### APPLICATIONS:

This keyboard provides full-size versatility in a rugged, compact design with the added convenience of an integrated touchpad. For working in low-light areas, it is with LED backlighting. Engineered for NEMA 4X protection from dust, water and corrosive liquids. This keyboard is ideal for use in environments ranging from manufacturing to material handling to medical settings. Its tactile keys allows for easy data entry, while its robust aluminum housing protects it against any hazardous environment.

**MEDICAL:** lab, hospital, clinic, dental, such as carts, diagnostic equipments, operation rooms, dialysis centers etc;

**MATERIAL HANDLING:** mobile keyboard, data entry, assembly line etc

**MILITARY:** Army, Navy, Air force

**INDUSTRIAL:** Industrial automation, pharmaceutical, oil and gas, food and beverage, clean or dirty manufacturing environments, warehouses

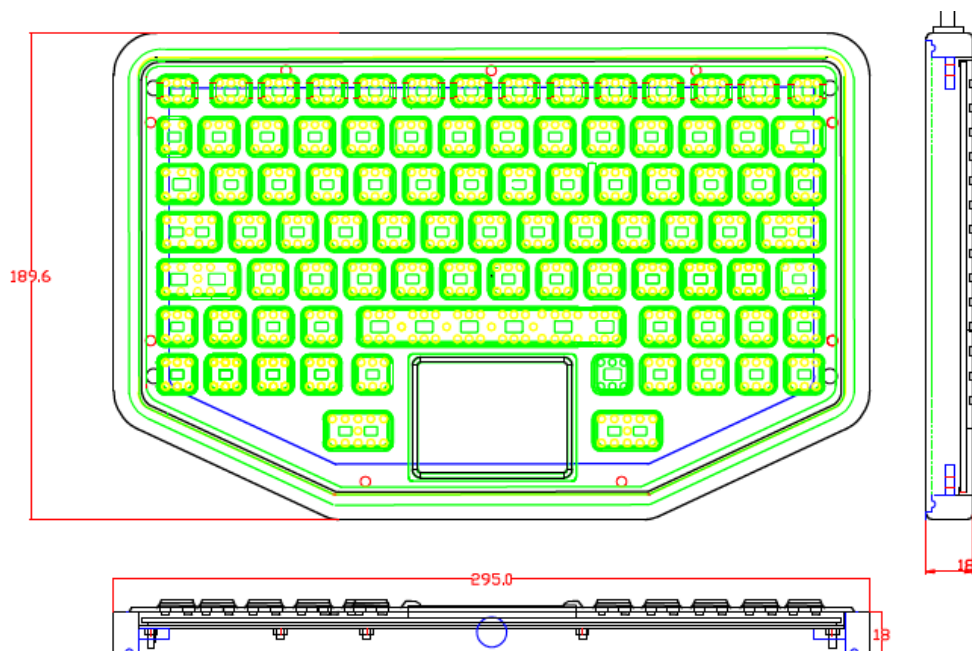

## PRI-KYB-M275RTP-FNK-IL-MDT

**DESCRIPTION:** 89 keys IP68 dynamic sealed & ruggedized silicone rubber industrial keyboard with full keyboard functionalities with sealed & ruggedized tough touchpad, 12 FN keys are on the top line for easy operation, with industrial PCB with carbon-on-gold key switch technology with long stroke (1.50mm) with extremely good tactile feeling for fast and accurate data input without any noise, with durable coating & antimicrobial keyboard surface withstand to most chemicals and liquids under harsh environment, CLEAN key for easy cleaning via lock/disable the entire keyboard without needing to take the keyboard from PC, adjustable industrial backlight optional, wired keyboard. Mountable desk top version with robust poly carbonate case, industrial level. Adjustable backlight optional, military level optional.

**DIMENSIONS :** 304.40mm x 195.80mm x (22.34mm-47.33mm) (L x W x H)

### APPLICATIONS:

This keyboard provides full-size versatility in a rugged, compact design with the added convenience of an integrated touchpad. For working in low-light areas, it is also available with optional LED backlighting. Engineered for NEMA 4X protection from dust, water and corrosive liquids. This keyboard is ideal for use in environments ranging from manufacturing to material handling to medical settings. The tactile keys allows for easy data entry, while its robust poly carbonate case protects it against any hazardous environment.

**MEDICAL:** lab, hospital, clinic, dental, such as carts, diagnostic equipment, operation rooms, dialysis centers etc;

**MATERIAL HANDLING:** mobile keyboard, data entry, assembly line etc

**MILITARY:** Army, Navy, Air force

**INDUSTRIAL:** Industrial automation, pharmaceutical, oil and gas, food and beverage, clean or dirty manufacturing environments, warehouses

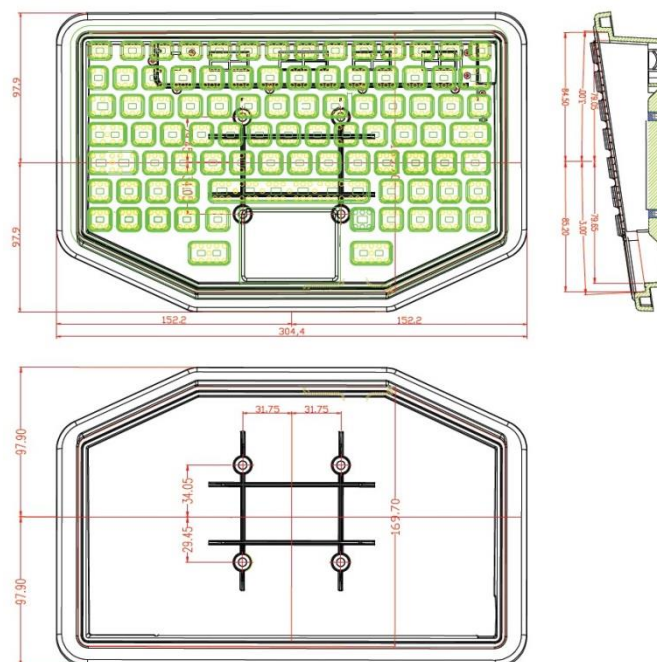



## PRI-KYB-M275RTP-FNK-AL-ML-MDT

**DESCRIPTION:** 89 keys IP68 dynamic sealed and ruggedized silicone rubber keyboard with full keyboard functionalities with sealed & ruggedized tough touchpad for fast and accurate cursor position, 12 FN keys (F1, F2...F11,F12) are on the top line for easy operations, with gold PCB with carbon-on-gold key switch technology with long stroke (1.50mm) with extremely good tactile feeling for fast and accurate data input without any noise, with durable coating & antimicrobial keyboard surface withstand to most chemicals and liquids under harsh environment, CLEAN key for easy cleaning via locking/disable the entire keyboard without needing to take the keyboard from PC, movable stand alone desk top version with IP68 dynamic washable sealed aluminum metal housing with sand blasting & oxygenation surface treatment, Military Level, adjustable backlight optional, industrial level optional.

**DIMENSIONS :** 295.00mm x 189.60mm x 18.00mm (L x W x H)

### APPLICATIONS:

This keyboard provides full-size versatility in a rugged, compact design with the added convenience of an integrated touchpad. For working in low-light areas, it is also available with optional LED backlighting. Engineered for NEMA 4X protection from dust, water and corrosive liquids. This keyboard is ideal for use in environments ranging from manufacturing to material handling to medical settings. Its tactile keys allows for easy data entry, while its robust aluminum housing protects it against any hazardous environment.

**MEDICAL:** lab, hospital, clinic, dental, such as carts, diagnostic equipments, operation rooms, dialysis centers etc;

**MATERIAL HANDLING:** mobile keyboard, data entry, assembly line etc

**MILITARY:** Army, Navy, Air force

**INDUSTRIAL:** Industrial automation, pharmaceutical, oil and gas, food and beverage, clean or dirty manufacturing environments, warehouses

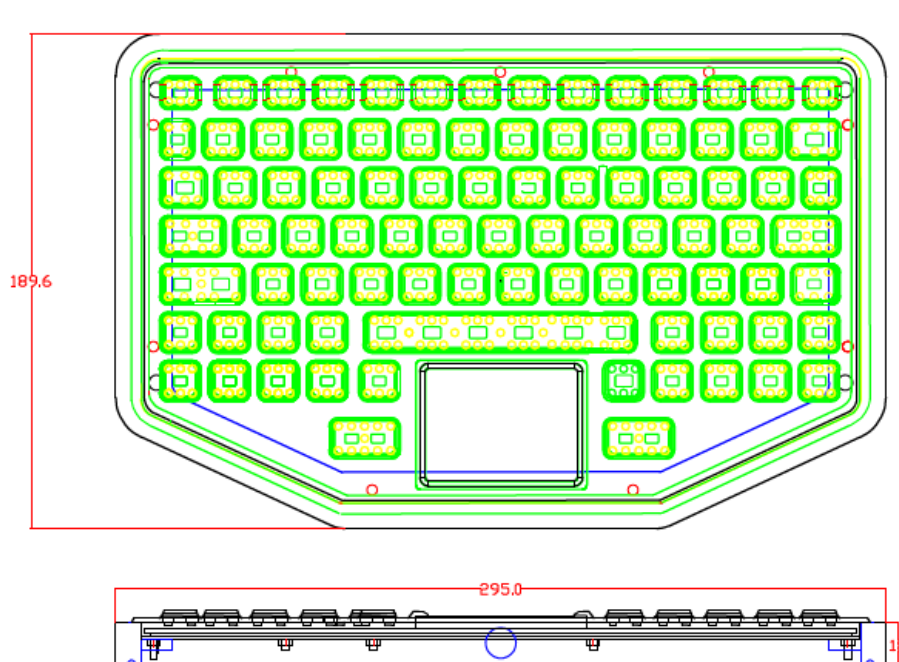

## PRI-KYB-M275RTP-FNK-BLT-AL-IL-MDT

**DESCRIPTION:** 89 keys IP68 dynamic sealed and ruggedized silicone rubber industrial keyboard with full keyboard functionalities with sealed & ruggedized tough touchpad for fast and accurate cursor position, 12 FN keys (F1, F2...F11,F12) are on the top line for easy operations, with industrial PCB with carbon-on-gold key switch technology with long stroke (1.50mm) with extremely good tactile feeling for fast and accurate data input without any noise, with durable coating & antimicrobial keyboard surface withstand to most chemicals and liquids under harsh environment, CLEAN key for easy cleaning via locking/disable the entire keyboard without needing to take the keyboard from PC, movable stand alone desk top version with IP68 dynamic washable sealed aluminum metal housing with sand blasting & oxygenation surface treatment, adjustable industrial backlight included, industrial level. Military level optional.

**DIMENSIONS:** 295.00mm x 189.60mm x 18.00 mm (L x W x H)

### APPLICATIONS:

This keyboard provides full-size versatility in a rugged, compact design with the added convenience of an integrated touchpad. For working in low-light areas, it is with LED backlighting. Engineered for NEMA 4X protection from dust, water and corrosive liquids. This keyboard is ideal for use in environments ranging from manufacturing to material handling to medical settings. Its tactile keys allows for easy data entry, while its robust aluminum housing protects it against any hazardous environment.

**MEDICAL:** lab, hospital, clinic, dental, such as carts, diagnostic equipments, operation rooms, dialysis centers etc;

**MATERIAL HANDLING:** mobile keyboard, data entry, assembly line etc

**MILITARY:** Army, Navy, Air force

**INDUSTRIAL:** Industrial automation, pharmaceutical, oil and gas, food and beverage, clean or dirty manufacturing environments, warehouses

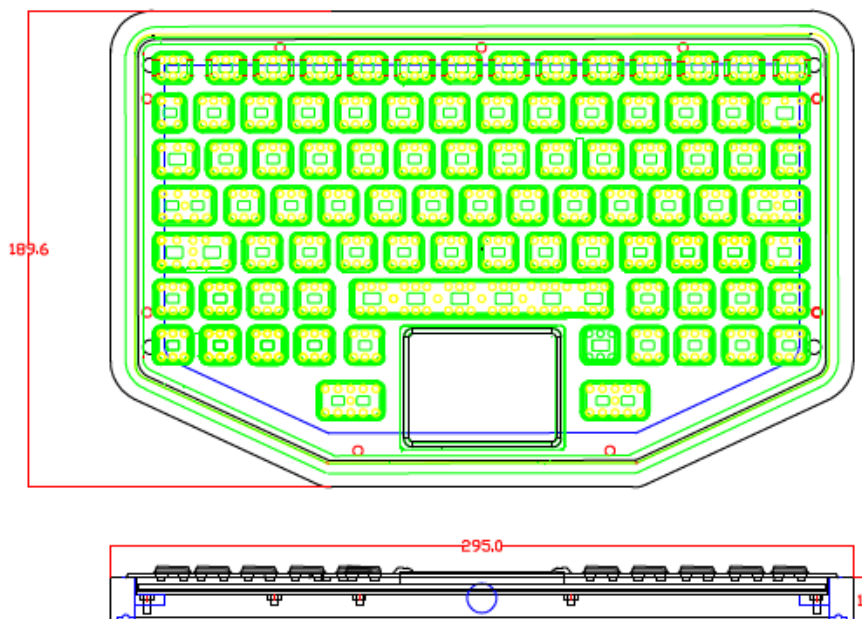

## PRI-KYB-M276NKP-BLT-ML

**DESCRIPTION:** 62 keys IP65 dynamic sealed & ruggedized silicone rubber military keyboard with industrial PCB included, NO 12 function keys and numeric keypad included, military PCB electronics with carbon-on-gold key switch technology with long stroke (1.50mm) with extremely good tactile feeling for fast and accurate data input without any noise, with durable coating & anti-microbial keyboard surface withstand to most chemicals and liquids under harsh environment, with 2 backlight side function keypad optional.

**DIMENSIONS:** 276mm x 65mm (L x W )

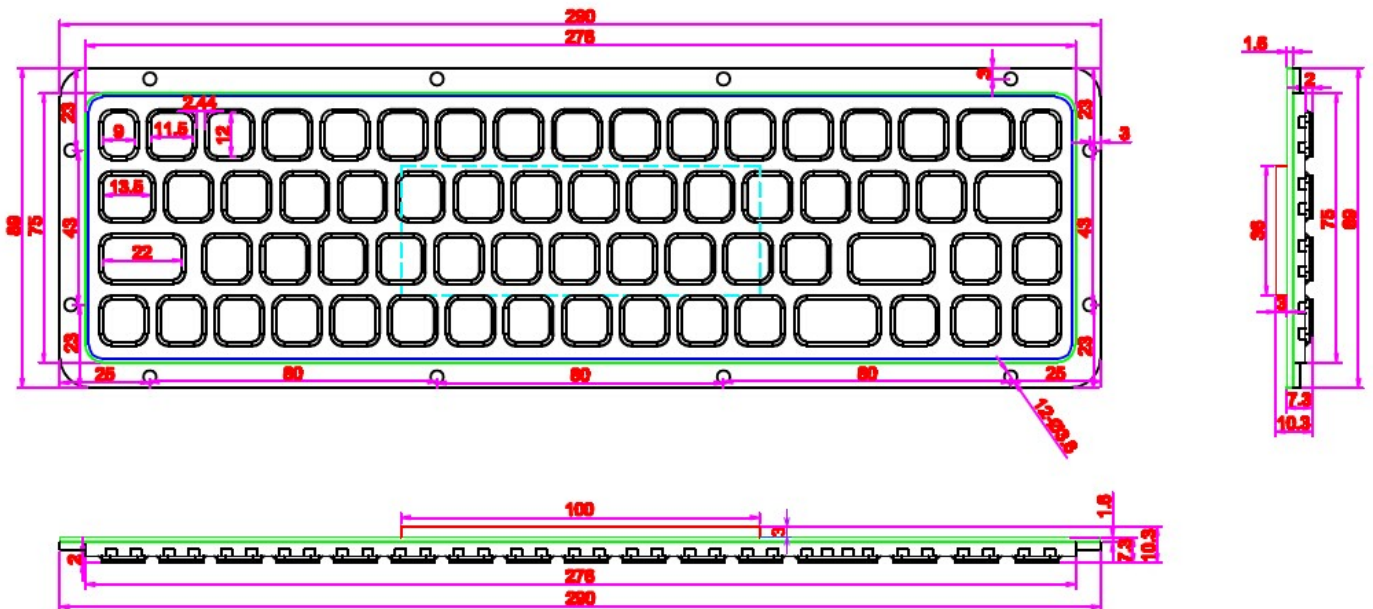

## PRI-KYB-M276RTP-FNK-BLT-ML-OEM

**DESCRIPTION:** 89 keys IP65 dynamic sealed and ruggedized industrial silicone rubber Hygienic keyboard with full keyboard functionalities with sealed and ruggedized tough touchpad for fast and accurate cursor position, with industrial PCB with carbon-on-gold key switch technology with long stroke (1.50mm) with extremely good tactile feeling for fast and accurate data input without any noise, with durable coating & antimicrobial keyboard surface withstand to most chemicals and liquids under harsh environment, **FN + Clean key to lock/disable** the keyboard for easy cleaning without needing to take the keyboard from PC, top panel mounted with optional stainless steel back plate sealed with top ruggedized industrial silicone cover & industrial PCB for ruggedized structure and easy mounting and sealing, stainless steel housing protects the electronics controller. Adjustable industrial backlight included, military level.

**Dimensions:** 274.60mm x 146.50mm (L x W )

### APPLICATIONS:

This ruggedized and compact design keyboard can be good for working in low-light areas, it is also available with optional LED backlighting. Engineered for NEMA 4X protection from dust, water and corrosive liquids. This keyboard is ideal for below wide applications:

**MEDICAL:** lab, hospital, clinic, dental, such as carts, diagnostic equipment, operation rooms, dialysis centers etc;

**MATERIAL HANDLING:** mobile keyboard, data entry, assembly line etc

**MILITARY:** Army, Navy, Air force

**INDUSTRIAL:** Industrial automation, pharmaceutical, oil and gas, food and beverage, clean or dirty manufacturing environments, warehouses

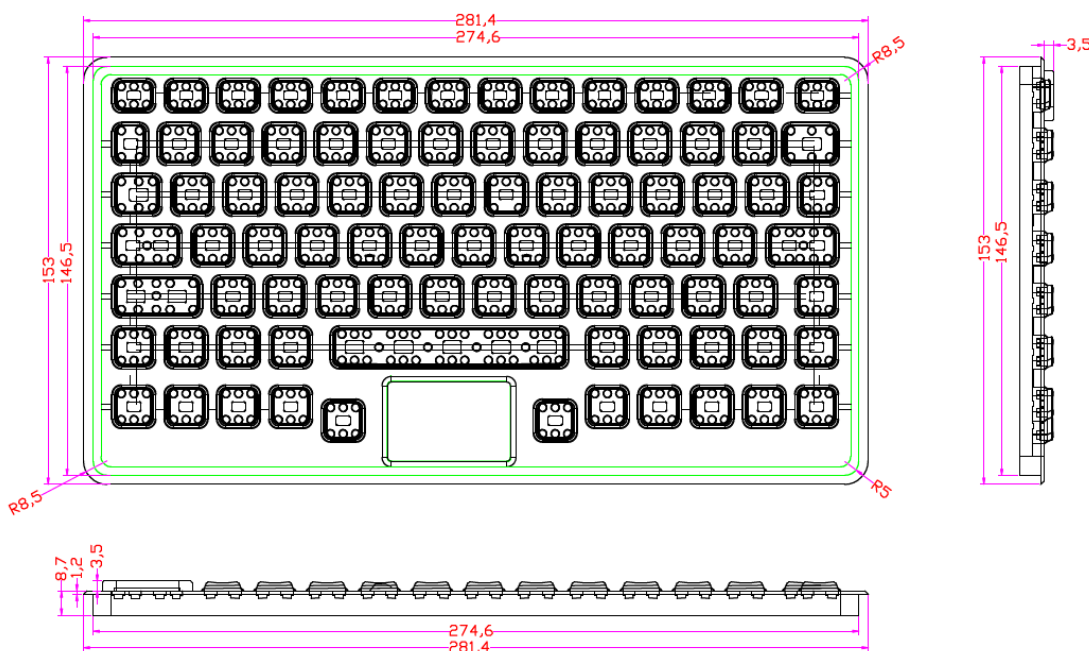



## PRI-KYB-M276RTP-FNK-BLT-ML-FDT

**DESCRIPTION:** 89 keys IP68 dynamic water proof sealed & ruggedized silicone rubber military keyboard with full keyboard functionalities with sealed & ruggedized tough touchpad for fast and accurate cursor position, 12 FN keys (F1, F2...F11,F12) are on the top line for easy operation, with military PCB with carbon-on-gold key switch technology with long stroke (1.50mm) with extremely good tactile feeling for fast and accurate data input without any noise, with durable coating & antimicrobial keyboard surface withstand to most chemicals and liquids under harsh environment, FN + CLEAN key for easy cleaning via lock/disable the entire keyboard without needing to take the keyboard from PC, adjustable backlight included, VESA mountable super flat desk top version with robust ABS polycarbonate case, military level, industrial level optional.

**Dimensions:** 289.66mm x 160 x 22.36mm (L x W )

### APPLICATIONS:

This ruggedized and compact design keyboard can be good for working in low-light areas, it is also available with optional LED backlighting. Engineered for NEMA 4X protection from dust, water and corrosive liquids. This keyboard is ideal for below wide applications:

**MEDICAL:** lab, hospital, clinic, dental, such as carts, diagnostic equipment, operation rooms, dialysis centers etc;

**MATERIAL HANDLING:** mobile keyboard, data entry, assembly line etc

**MILITARY:** Army, Navy, Air force

**INDUSTRIAL:** Industrial automation, pharmaceutical, oil and gas, food and beverage, clean or dirty manufacturing environments, warehouses

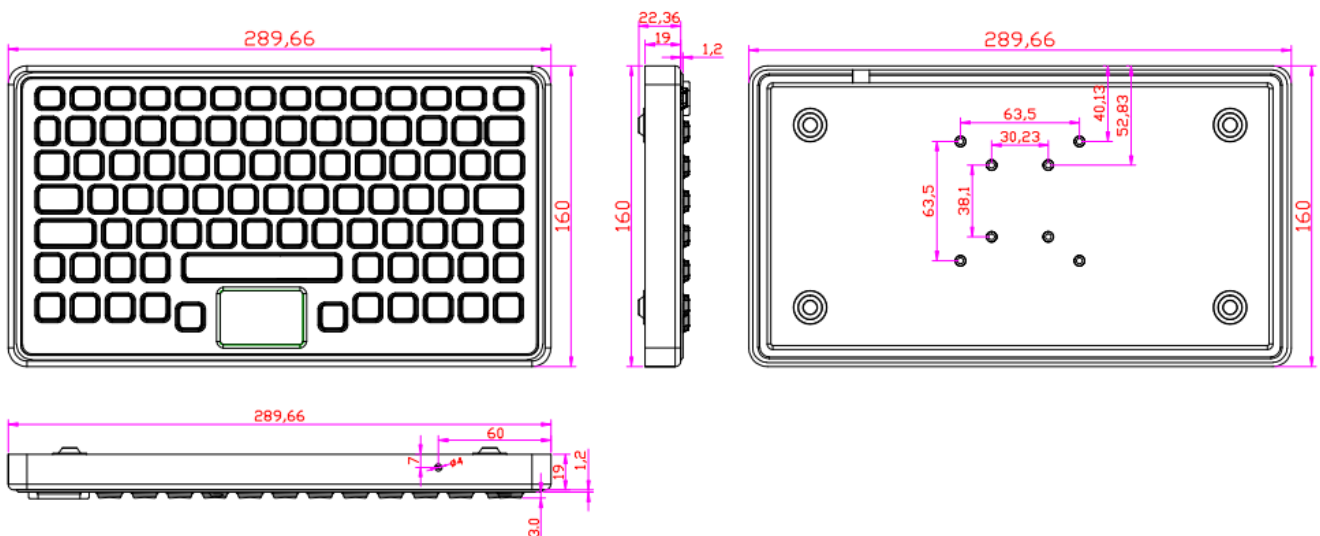

## PRI-KYB-M300NKP-FNK-IL

**DESCRIPTION:** 90 keys IP65 dynamic sealed & ruggedized industrial silicone rubber keyboard with integrated function keys (F1, F2...F11,F12) and industrial PCB with carbon-on-gold key switch technology with long stroke (1.50mm) with extremely good tactile feeling for fast and accurate data input without any noise, with durable coating & antimicrobial keyboard surface withstand to most chemicals and liquids under harsh environment, Clean key for easy cleaning via lock/disable the keyboard without needing to take away the keyboard from PC, panel mounted with aluminum back plate with mounting holes and sealed with top ruggedized industrial silicone cover & Industrial carbon-on-gold PCB.

**DIMENSIONS :** 331.0mm x 123.0mm(L x W )

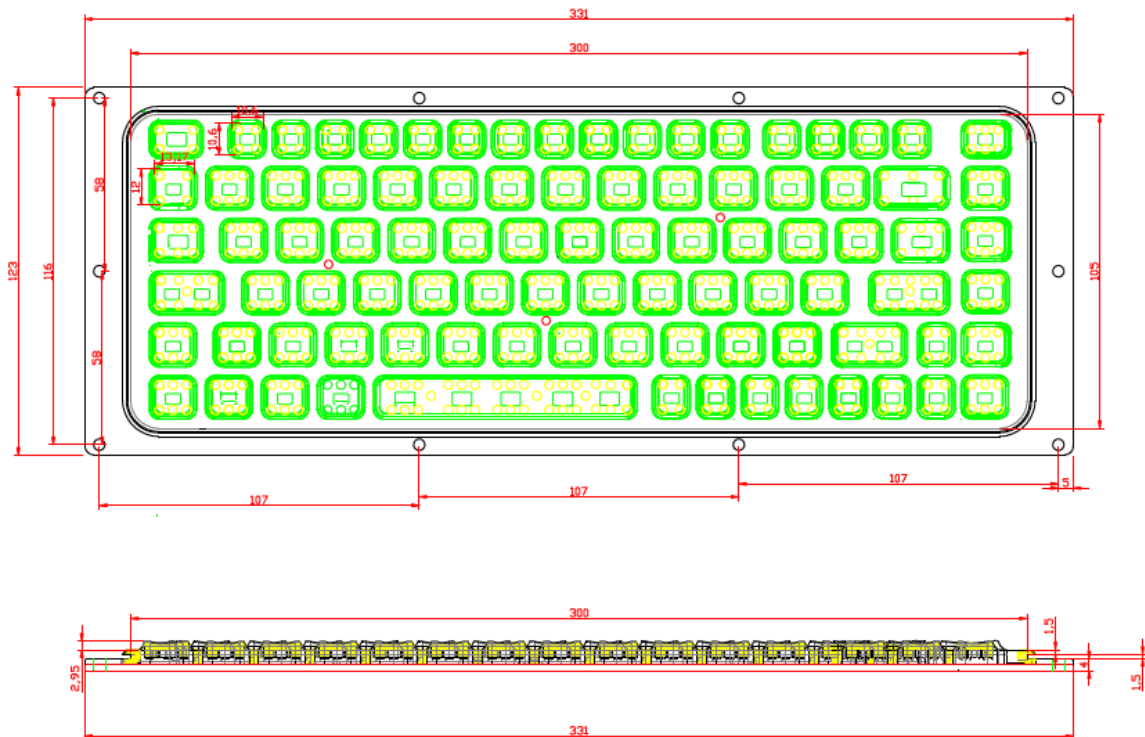

## PRI-KYB-M368-OTBM-FNK-MDT

**DESCRIPTION:** 86 keys IP68 dynamic sealed & ruggedized silicone rubber industrial keyboard with IP68 dynamic rated 16.0mm washable optical trackball module with 800 DPI resolutions for fast and accurate cursor position, 3 mouse buttons designed for right & left clicking and scrolling up and down with ball rolling, 12 function keys on top line for easy operation, industrial PCB with carbon-on-gold key switch technology with long stroke (1.50mm) with extremely good tactile feeling for fast and accurate data input without any noise, with durable coating & antimicrobial keyboard surface withstand to most chemicals and liquids under harsh environment, CLEAN key for easy cleaning via locking/disable the entire keyboard without needing to take the keyboard from PCB, movable stand alone desk top version with IP68 dynamic washable sealed aluminum metal housing with sand blasting & oxygenation surface treatment, adjustable industrial backlight optional. Industrial level

- **Number of Keys:** 86
- **Clean key**
  - Prevents data from being sent while the keyboard is wiped down, allowing user to clean at any interval with minimal downtime
  - User is notified of 'lock down mode' by brightly lit CLEAN KEY
- **G.W.:** 1.30 kgs
- **Dimensions:** 368.0mm x 142.90mm x (18.0mm-31.0mm) (L x W x H)



Product Name		IP Rate	
PRI-KYB-M368-OTBM-FN K-MDT	Keyboard; Optical trackball; Function keys; Desk top keyboard	PS/2;USB	IP68 Dynamic
Other language versions/interfaces/configuration available on request			

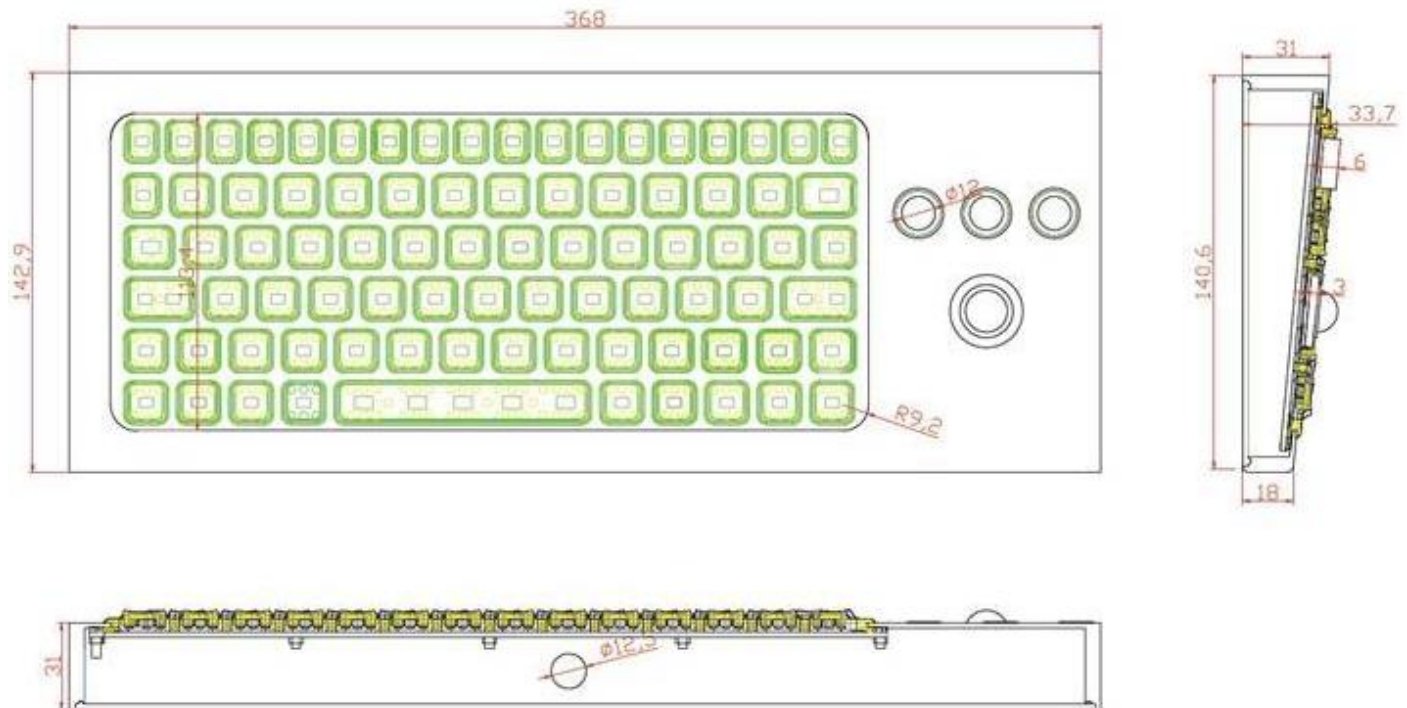

## PRI-KYB-M368-OTBM-FNK-BLT-MDT

**DESCRIPTION:** 86 keys IP68 dynamic sealed & ruggedized industrial silicone rubber industrial keyboard with full keyboard functionalities, IP68 dynamic rated 16.0mm optical trackball module with 800 DPI resolutions for fast and accurate cursor position, 12 function keys and industrial PCB with carbon-on-gold key switch technology with long stroke (1.50mm) with extremely good tactile feeling for fast and accurate data input without any noise, with durable coating & antimicrobial keyboard surface withstand to most chemicals and liquids under harsh environment, Clean key for easy cleaning via locking/disable the entire keyboard without needing to take the keyboard from PCB, movable stand alone desk top version with IP68 dynamic washable sealed aluminum metal housing with sand blasting & oxygenation surface treatment, adjustable industrial backlight included, industrial level.



- **Number of Keys:** 86
- **Clean key**
  - Prevents data from being sent while the keyboard is wiped down, allowing user to clean at any interval with minimal downtime
  - User is notified of 'lock down mode' by brightly lit CLEAN KEY
- **G.W.:** 1.50 kgs
- **Dimensions:** 368.0mm x 142.90mm x (18.0mm-31.0mm) (L x W x H)

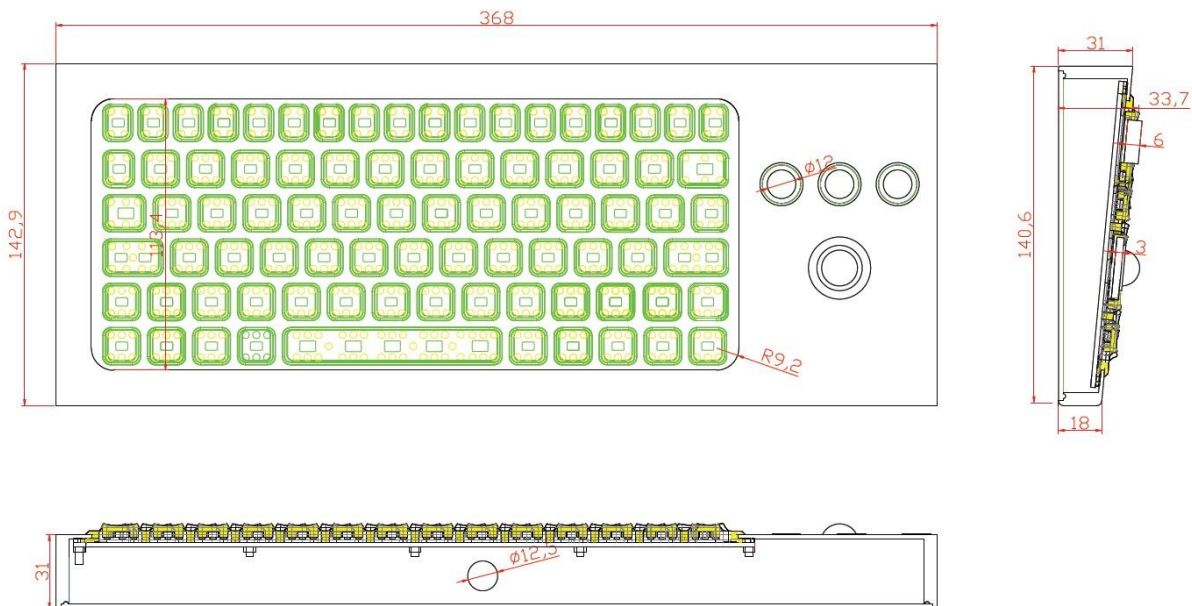

Product Name		IP Rate	
PRI-KYB-M368-OTBM-FNK-MDT-BLT	Keyboard; Optical trackball; Function keys; Desk top keyboard;Backlight	PS/2;USB	IP68 Dynamic
Other language versions/interfaces/configuration available on request			



## PRI-KYB-M375NKP-FNK-MDT

**DESCRIPTION:** 106 keys IP68 dynamic sealed & ruggedized industrial silicone rubber Hygienic keyboard ,integrated sealed numeric keypad, function keys and industrial PCB with carbon-on-gold key switch technology with long stroke (1.50mm) with extremely good tactile feeling for fast and accurate data input without any noise, with durable coating & antimicrobial keyboard surface withstand to most chemicals and liquids under harsh environment, Clean key for easy cleaning, movable stand alone desk top version, adjustable industrial backlight optional.

### APPLICATIONS:

This keyboard provides full-size versatility in a rugged, compact design with the added convenience of an integrated numeric keypad. For working in low-light areas, it is also available with optional LED backlighting. Engineered for NEMA 4X protection from dust, water and corrosive liquids. This keyboard is ideal for use in environments ranging from manufacturing to material handling to medical settings. Its numeric pad allows for easy data entry.

- **MEDICAL:** lab, hospital, clinic, dental, such as carts, diagnostic equipments, operation rooms, dialysis centers etc;
- **MATERIAL HANDLING:** mobile keyboard, data entry, assembly line etc
- **MILITARY:** Army, Navy, Air force
- **INDUSTRIAL:** Industrial automation, pharmaceutical, oil and gas, food and beverage, clean or dirty manufacturing environments, warehouses
- **OTHER INDUSTRIES**



- **Number of Keys:** 106
- **Clean key**  
-Prevents data from being sent while the keyboard is wiped down, allowing user to clean at any interval with minimal downtime  
-User is notified of 'lock down mode' by brightly lit CLEAN KEY
- **G.W.:** 1.80 kgs
- **Dimensions:** .379.0mmx142.8mmx15.5mm(L x W x H)

Product Name		IP Rate	
PRI-KYB-M375NKP-FNK-I L-MDT	Keyboard; Numeric Keypad; Function keys; Desk top keyboard	PS/2;USB	IP68 Dynamic
Other language versions/interfaces/configuration available on request			

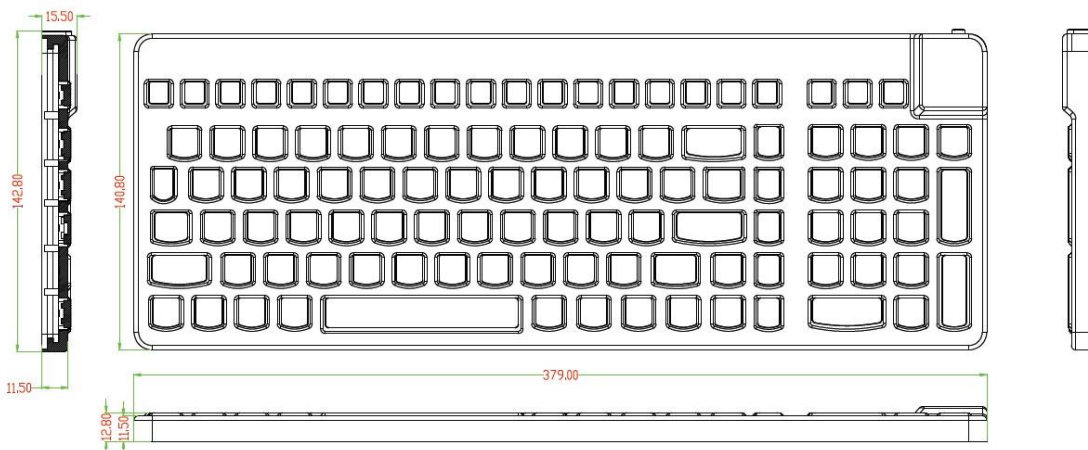

## PRI-KYB-M367NKP-FNK-IL-OEM

**DESCRIPTION:** 119 keys IP65 dynamic sealed & ruggedized industrial silicone rubber industrial keyboard, integrated sealed numeric keypad, 24 function keys (F1, F2...F11, F12...F23, F24) and industrial PCB with carbon-on-gold key switch technology with long stroke (1.50mm) with extremely good tactile feeling for fast and accurate data input without any noise, with durable coating & antimicrobial keyboard surface withstand to most chemicals and liquids under harsh environment, Clean key for easy cleaning via locking/disable the whole keyboard without needing to take away the keyboard from PC, panel mounted solution. Adjustable backlight optional, military level optional.

**DIMENSIONS :** 367.0mm x 128.8.0mm(L x W )

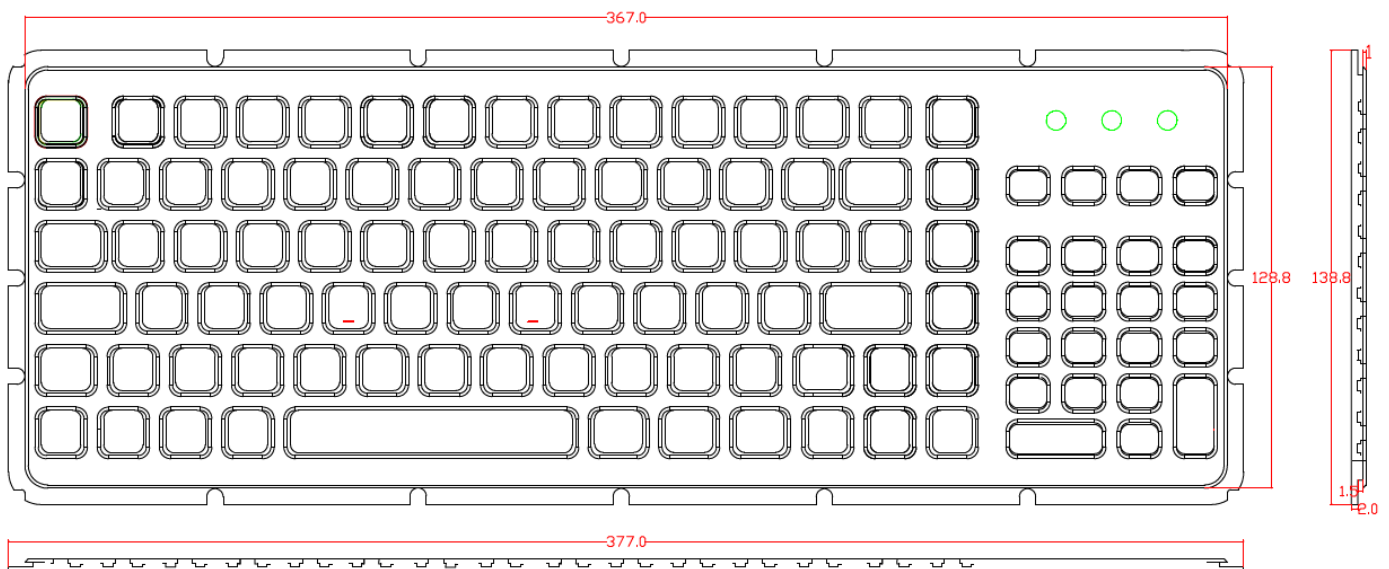

## PRI-KYB-M376NKP-FNK-FM-SLS-IL-MDT

**DESCRIPTION:** 119 keys IP67 dynamic sealed & ruggedized silicone rubber industrial keyboard, integrated numeric keypad, 24 function keys (F1, F2...F11, F12...F23, F24) on the top line for easy operation, industrial PCB with carbon-on-gold key switch technology with long stroke (1.50mm) with extremely good tactile feeling for fast and accurate data input without any noise, with durable coating & antimicrobial keyboard surface treatment withstand to most chemicals and liquids under harsh environment, FN+ CLEAN combination key for easy cleaning via locking/disable the entire keyboard without needing to take away the keyboard from PC, top panel mountable desk top version with IP67 dynamic sealed stainless steel metal housing with brushed surface treatment, with stainless steel mounting plate on both sides for panel mounting optional, adjustable industrial backlight optional. Military level optional.

**DIMENSIONS:** 388.0mm x 188.0mm x 23.20mm (L x W x H)

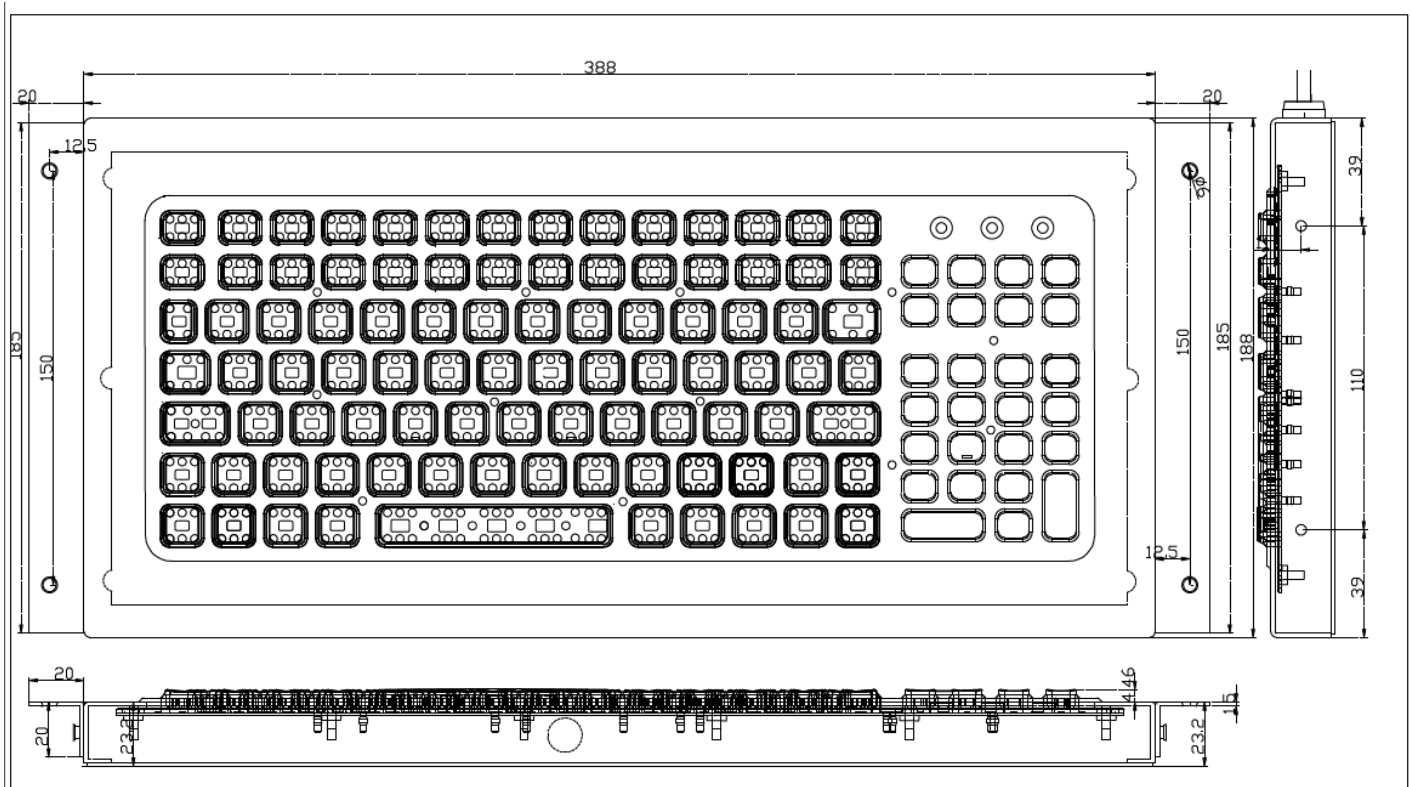

## PRI-KYB-M376NKP-FNK-SLS-IL-MDT

**DESCRIPTION:** 119 keys IP67 dynamic sealed & ruggedized silicone rubber industrial keyboard, integrated numeric keypad, 24 function keys (F1, F2...F11, F12...F23, F24) on the top line for easy operation, industrial PCB with carbon-on-gold key switch technology with long stroke (1.50mm) with extremely good tactile feeling for fast and accurate data input without any noise, with durable coating & antimicrobial keyboard surface treatment withstand to most chemicals and liquids under harsh environment, CLEAN key for easy cleaning via locking/disable the entire keyboard without needing to take away the keyboard from PC, standard alone movable desk top version with IP67 dynamic sealed stainless steel metal housing with brushed surface treatment, adjustable industrial backlight optional. Military level optional.

**DIMENSIONS:** 388.0mm x 188.0mm x 23.20mm (L x W x H)

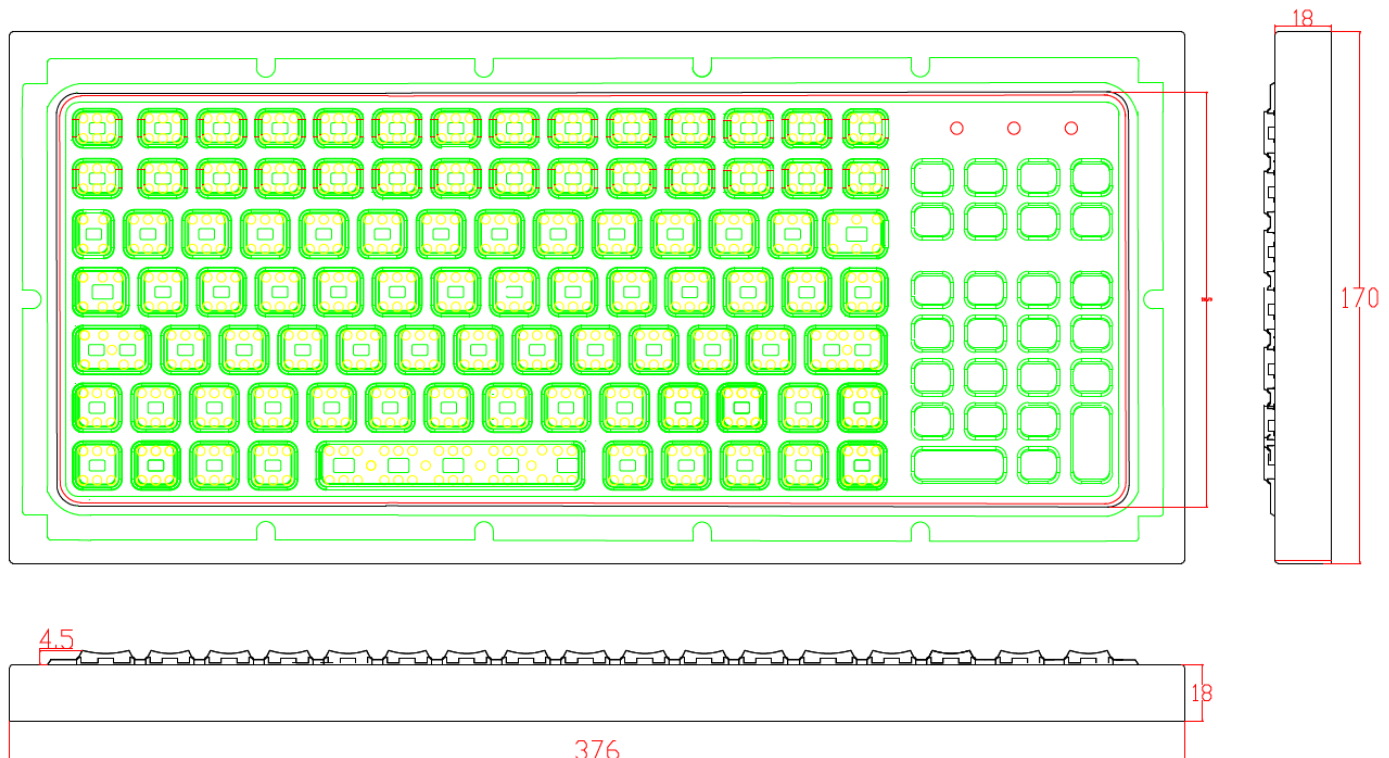



## PRI-KYB-M375NKP-FNK-BLT-MDT

**DESCRIPTION:** 106 keys IP68 dynamic sealed & ruggedized industrial silicone rubber Hygienic keyboard ,integrated sealed numeric keypad, function keys and industrial PCB with carbon-on-gold key switch technology with long stroke (1.50mm) with extremely good tactile feeling for fast and accurate data input without any noise, with durable coating & antimicrobial keyboard surface withstand to most chemicals and liquids under harsh environment, Clean key for easy cleaning via locking/disable the whole keyboard without needing to take away the keyboard from PC, panel mounted solution, movable stand alone desk top version, adjustable industrial backlight included.

**DIMENSIONS :** 379.0mm x 142.8mm x 15.5mm (L x W x H)

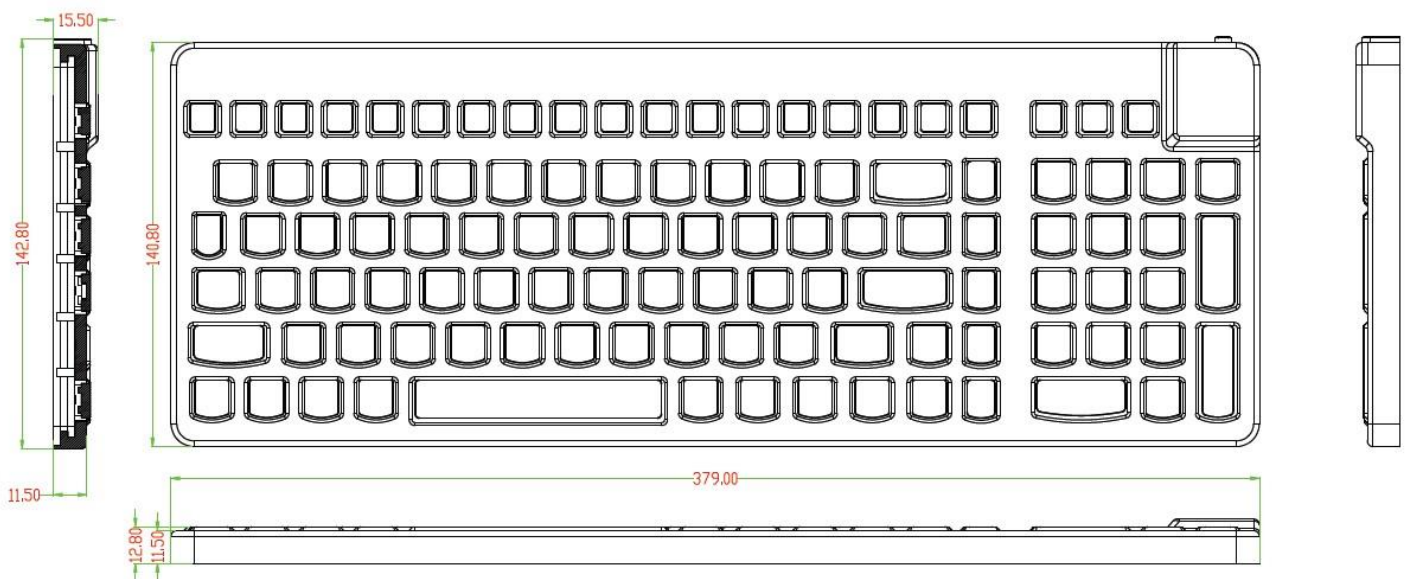

## PRI-KYB-M376NKP-FNK-AL-MDT

**DESCRIPTION:** 119 keys IP68 dynamic sealed & ruggedized industrial silicone rubber industrial keyboard, integrated numeric keypad, 24 function keys (F1, F2...F11, F12...F23, F24) and industrial PCB with carbon-on-gold key switch technology with long stroke (1.50mm) with extremely good tactile feeling for fast and accurate data input without any noise, with durable coating & antimicrobial keyboard surface withstand to most chemicals and liquids under harsh environment, Clean key for easy cleaning via locking/disable the entire keyboard, movable stand alone desk top version with IP68 dynamic washable sealed stainless steel metal housing with boused surface treatment, adjustable industrial backlight optional. Military level optional.

### APPLICATIONS:

This keyboard provides full-size versatility in a rugged, compact design with the added convenience of an integrated numeric keypad. For working in low-light areas, it is also available with optional LED backlighting. Engineered for NEMA 4X protection from dust, water and corrosive liquids. This keyboard is ideal for use in environments ranging from manufacturing to material handling to medical settings. Its numeric pad allows for easy data entry.

**MEDICAL:** lab, hospital, clinic, dental, such as carts, diagnostic equipments, operation rooms, dialysis centers etc; **MATERIAL**

**HANDLING:** mobile keyboard, data entry, assembly line etc

**MILITARY:** Army, Navy, Air force

**INDUSTRIAL:** Industrial automation, pharmaceutical, oil and gas, food and beverage, clean or dirty manufacturing environments, warehouses

**OTHER INDUSTRIES**

- **Number of Keys:** 119
- **Clean key**  
-Prevents data from being sent while the keyboard is wiped down, allowing user to clean at any interval with minimal downtime  
-User is notified of 'lock down mode' by brightly lit CLEAN KEY
- **G.W.:** 1.60 kgs
- **Dimensions:** 376.0mm x 170.0mm x 18.0mm (L x W x H)



Product Name		IP Rate	
PRI-KYB-M376NKP-FNK-MDT-AL	Keyboard; Numeric Keypad; Function keys; Desk top keyboard	PS/2;USB	IP68 Dynamic
Other language versions/interfaces/configuration available on request			



## PRI-KYB-M390NKP-FNK-BLT-MDT

**DESCRIPTION:** 106 keys IP68 dynamic sealed & ruggedized industrial silicone rubber Hygienic keyboard, with integrated sealed numeric keypad, function keys (F1, F2...F11, F12) are on upper line; with industrial PCB with carbon-on-gold key switch technology with long stroke (1.50mm) with extremely good tactile feeling for fast and accurate data input without any noise, with durable coating & antimicrobial keyboard surface withstand to most chemicals and liquids under harsh environment, Clean key for easy cleaning via disable/lock the keyboard without needing to take away the keyboard from PC, movable stand alone desk top version sealed and ruggedized with 5.0mm thickness aluminum back plate with sand blasting & oxygenation surface treatment, adjustable industrial backlight included.

**DIMENSIONS :** 390.0mm x 154.0mm x 19.0mm (L x W x H)

### APPLICATIONS:

This keyboard provides full-size versatility in a rugged, compact design with the added convenience of an integrated numeric keypad. For working in low-light areas, it is with LED backlighting. Engineered for NEMA 4X protection from dust, water and corrosive liquids. This keyboard is ideal for use in environments ranging from manufacturing to material handling to medical settings. Its numeric pad allows for easy data entry.

**MEDICAL:** lab, hospital, clinic, dental, such as carts, diagnostic equipments, operation rooms, dialysis centers etc;

**MATERIAL HANDLING:** mobile keyboard, data entry, assembly line etc

**MILITARY:** Army, Navy, Air force

**INDUSTRIAL:** Industrial automation, pharmaceutical, oil and gas, food and beverage, clean or dirty manufacturing environments, warehouses

**OTHER INDUSTRIES**

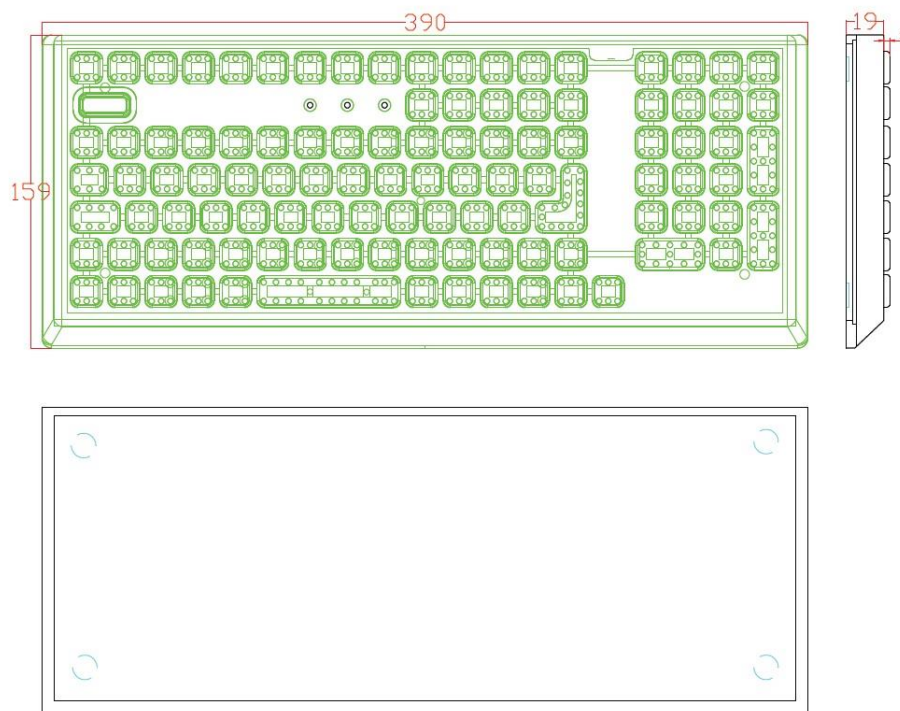

## PRI-KYB-M390NKP-FNK-MDT

**DESCRIPTION:** 106 keys IP68 dynamic sealed & ruggedized industrial silicone rubber Hygienic keyboard, with integrated sealed numeric keypad, function keys (F1, F2...F11, F12) are on upper line; with industrial PCB with carbon-on-gold key switch technology with long stroke (1.50mm) with extremely good tactile feeling for fast and accurate data input without any noise, with durable coating & antimicrobial keyboard surface withstand to most chemicals and liquids under harsh environment, Clean key for easy cleaning via Disable/lock the keyboard without needing to take the keyboard from PC, movable stand alone desk top version sealed and ruggedized with 5.0mm thickness aluminum back plate with sand blasting & oxygenation surface treatment, adjustable industrial backlight optional.

### APPLICATIONS:

This keyboard provides full-size versatility in a rugged, compact design with the added convenience of an integrated numeric keypad. For working in low-light areas, it is also available with optional LED backlighting. Engineered for NEMA 4X protection from dust, water and corrosive liquids. This keyboard is ideal for use in environments ranging from manufacturing to material handling to medical settings. Its numeric pad allows for easy data entry.

- **MEDICAL:** lab, hospital, clinic, dental, such as carts, diagnostic equipments, operation rooms, dialysis centers etc;
- **MATERIAL HANDLING:** mobile keyboard, data entry, assembly line etc
- **MILITARY:** Army, Navy, Air force
- **INDUSTRIAL:** Industrial automation, pharmaceutical, oil and gas, food and beverage, clean or dirty manufacturing environments, warehouses
- **OTHER INDUSTRIES**

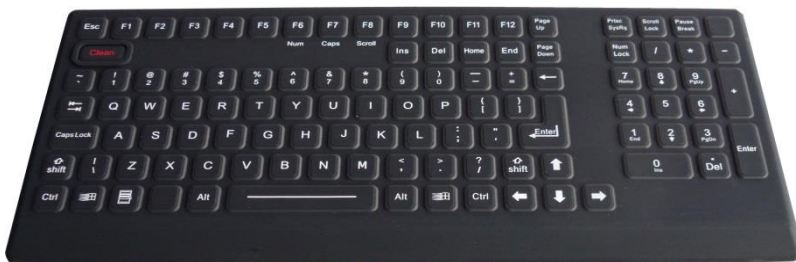

- **Number of Keys:** 106
- **Clean key**
  - Prevents data from being sent while the keyboard is wiped down, allowing user to clean at any interval with minimal downtime
  - User is notified of 'lock down mode' by brightly lit CLEAN KEY
- **Enclosure:** industrial silicone, Aluminum (rear side).
- **G.W.:** 1.40 kgs
- **Dimensions:** 390.0mm x 159.0mm x 19.0mm (L x W x H)

Product Name		IP Rate	
PRI-KYB-M390NKP-FNK -MDT	Keyboard; Numeric Keypad; Function keys; Desk top keyboard	PS/2;USB	IP68 Dynamic
Other language versions/interfaces/configuration available on request			

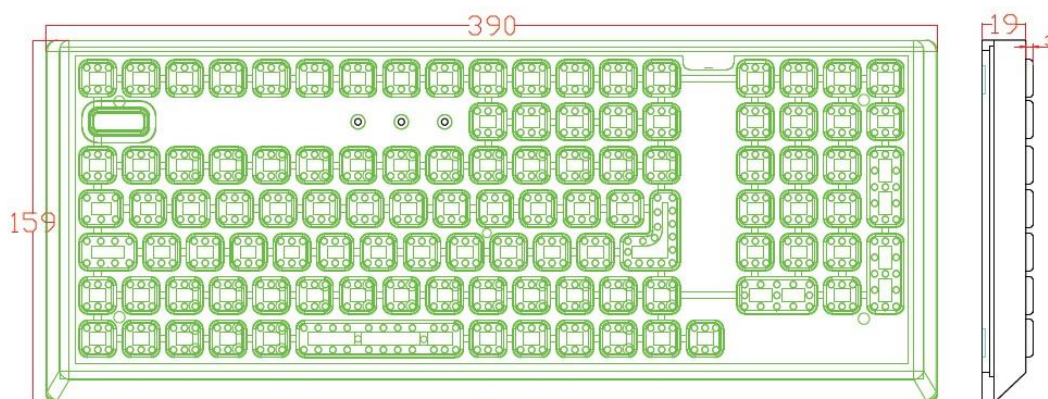



## PRI-KYB-M390RTP-NKP-FNK-BLT-MDT

**Description:** 108 keys IP68 dynamic rated & ruggedized industrial silicone rubber Hygienic keyboard with full keyboard functionalities, integrated numeric keypad, sealed & ruggedized tough touchpad for fast and accurate cursor position, function keys (F1, F2...F11, F12) are on upper line; with industrial PCB with carbon-on-gold key switch technology with long stroke (1.50mm) with extremely good tactile feeling for fast and accurate data input without any noise, with durable coating & antimicrobial keyboard surface withstand to most chemicals and liquids under harsh environment, Clean key for easy cleaning via lock/disable the keyboard without needing to take away the keyboard from PC, movable stand alone desk top version sealed & ruggedized with 5.0mm thickness aluminum back plate with sand blasting & oxygenation surface treatment, adjustable industrial backlight included.

**Dimension:** 390.0mm x 154.0mm x 19.0mm (L x W x H)

### APPLICATIONS:

This keyboard provides full-size versatility in a rugged, compact design with the added convenience of an integrated touchpad. For working in low-light areas, it is with LED backlighting. Engineered for NEMA 4X protection from dust, water and corrosive liquids. This keyboard is ideal for use in environments ranging from manufacturing to material handling to medical settings. Its numeric pad allows for easy data entry.

**MEDICAL:** lab, hospital, clinic, dental, such as carts, diagnostic equipments, operation rooms, dialysis centers etc;

**MATERIAL HANDLING:** mobile keyboard, data entry, assembly line etc

**MILITARY:** Army, Navy, Air force

**INDUSTRIAL:** Industrial automation, pharmaceutical, oil & gas, food & beverage, clean or dirty manufacturing environments, warehouses

**OTHER INDUSTRIES**

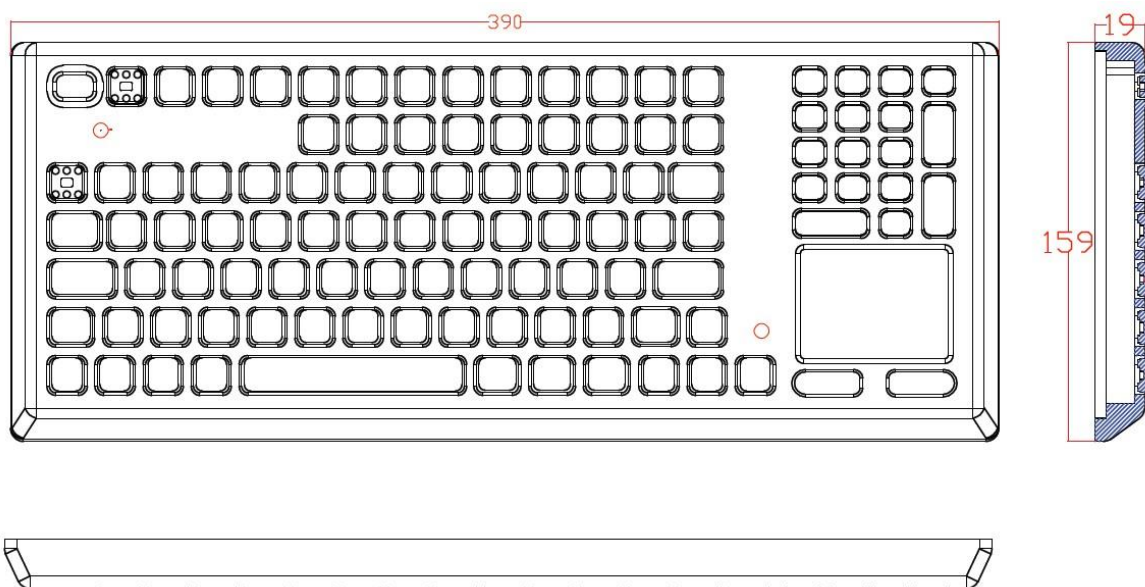
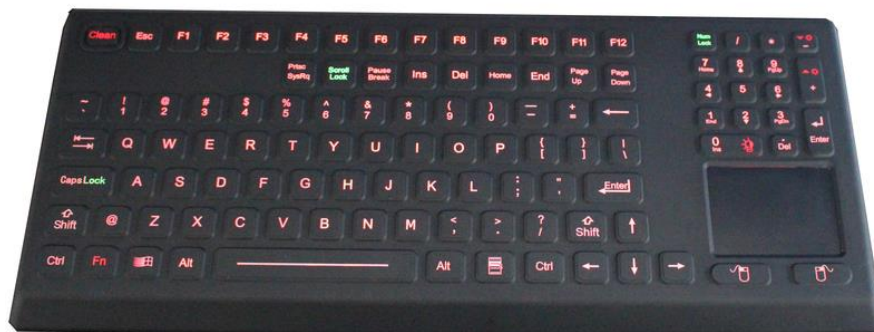

## PRI-KYB-M396RTP-NKP-FNK-BLT-MDT

**DESCRIPTION:** 106 keys IP68 dynamic rated & ruggedized industrial silicone rubber Hygienic keyboard with full keyboard functionalities, integrated numeric keypad, function keys, sealed & ruggedized tough touchpad for fast and accurate cursor position, industrial PCB with carbon-on-gold key switch technology with long stroke (1.50mm) with extremely good tactile feeling for fast and accurate data input without any noise, with durable coating & antimicrobial keyboard surface withstand to most chemicals and liquids under harsh environment, Clean key for easy cleaning via lock/disable the keyboard without needing to take away the keyboard from PC, mountable desk top version with robust polycarbonate case. Adjustable industrial backlight included.

**DIMENSIONS :** 396.0mm x 144.0mm x 20.0mm (L x W x H)

### APPLICATIONS:

This keyboard provides full-size versatility in a rugged, compact design with the added convenience of an integrated touchpad. For working in low-light areas, it is with LED backlighting. Engineered for NEMA 4X protection from dust, water and corrosive liquids. This keyboard is ideal for use in environments ranging from manufacturing to material handling to medical settings. Its large numeric pad allows for easy data entry, while its robust polycarbonate case protects it against any hazardous environment.

**MEDICAL:** lab, hospital, clinic, dental, such as carts, diagnostic equipment, operation rooms, dialysis centers etc;

**MATERIAL HANDLING:** mobile keyboard, data entry, assembly line etc

**MILITARY:** Army, Navy, Air force

**INDUSTRIAL:** Industrial automation, pharmaceutical, oil and gas, food and beverage, clean or dirty manufacturing environments, warehouses

OTHER

INDUSTRIES

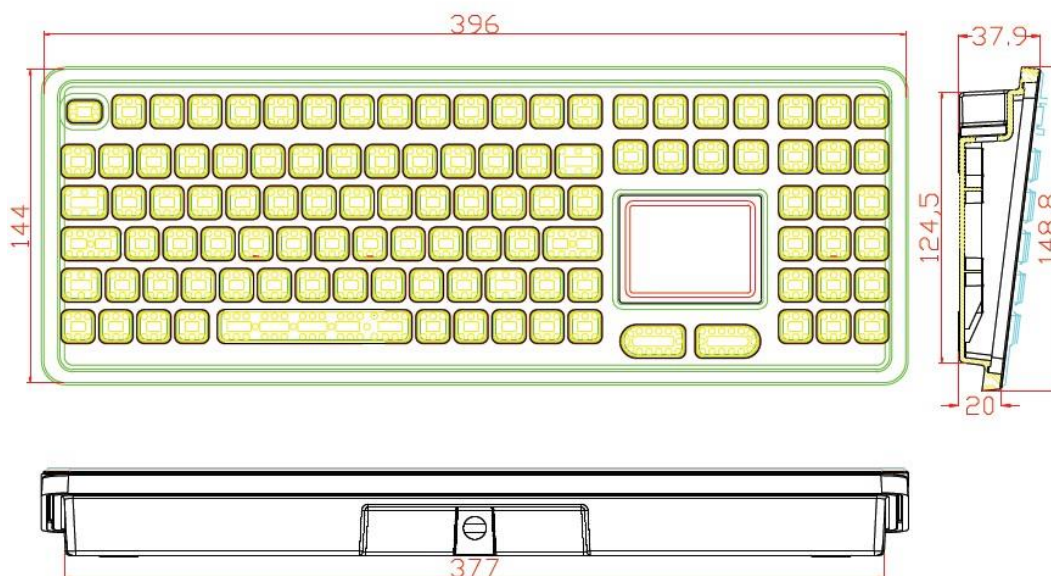

## PRI-KYB-M396-OTBM-NKP-FNK-BLT-MDT

**DESCRIPTION:** 106 keys IP68 dynamic sealed & ruggedized silicone rubber industrial keyboard with full keyboard functionalities function keys, integrated numeric keypad, IP68 dynamic rated 16.0mm optical trackball module with 800 DPI resolutions for fast and accurate cursor position with extremely smooth operation, industrial PCB electronics controller with carbon-on-gold key switch technology with long stroke (1.50mm) with extremely good tactile feeling for fast and accurate data input without any noise, with durable coating & antimicrobial keyboard surface withstand to most chemicals and liquids under harsh environment, FN + CLEAN combination key for easy cleaning via lock/disable the keyboard without needing to take away the keyboard from PC, VESA mountable desk top version with robust polycarbonate case, adjustable industrial backlight included.

**DIMENSIONS:** 399.0mm x 149.0mm x (20.0mm-37.90mm) (L x W x H)

### APPLICATIONS:

**MEDICAL:** lab, hospital, clinic, dental, such as carts, diagnostic equipments, operation rooms, dialysis centers etc;

**MATERIAL HANDLING:** mobile keyboard, data entry, assembly line etc

**MILITARY:** Army, Navy, Air force

**INDUSTRIAL:** Industrial automation, pharmaceutical, oil and gas, food and beverage, clean or dirty manufacturing environments, warehouses





## PRI-KYB-M399NKP-FNK-MDT

**DESCRIPTION:** 106 keys IP68 dynamic rated ruggedized industrial silicone rubber Hygienic keyboard, with integrated numeric keypad on right side, function keys on upper line, and industrial PCB with carbon-on-gold key switch technology with long stroke (1.50mm) with extremely good tactile feeling for fast and accurate data input without any noise, with durable coating & antimicrobial keyboard surface withstand to most chemicals and liquids under harsh environment, Clean key for easy cleaning, movable stand alone desk top version with robust polycarbonate case, adjustable industrial backlight optional.

### APPLICATIONS:

This keyboard provides full-size versatility in a rugged, compact design with the added convenience of an integrated numeric keypad. For working in low-light areas, it is also available with optional LED backlighting. Engineered for NEMA 4X protection from dust, water and corrosive liquids. This keyboard is ideal for use in environments ranging from manufacturing to material handling to medical settings. Its numeric pad allows for easy data entry.

- **MEDICAL:** lab, hospital, clinic, dental, such as carts, diagnostic equipment, operation rooms, dialysis centers etc;
- **MATERIAL HANDLING:** mobile keyboard, data entry, assembly line etc
- **MILITARY:** Army, Navy, Air force
- **INDUSTRIAL:** Industrial automation, pharmaceutical, oil and gas, food and beverage, clean or dirty manufacturing environments, warehouses



- **Number of Keys:** 106
- **OTHER INDUSTRIES**

Clean Key

-Prevents data from being sent while the keyboard is wiped down, allowing user to clean at any interval with minimal downtime  
 -User is notified of 'lock down mode' by brightly lit CLEAN KEY

- Enclosure: industrial silicone, Aluminum (rear side).
- **G.W.:** 1.20 kgs
- **Dimensions:** 399.0mm x 155.0mm x 20.0mm (L x W x H)

Product Name		IP Rate
PRI-KYB-M399NKP-FNK-MDT	Keyboard; Numeric Keypad; Function keys; Desk top keyboard	PS/2;USB IP68 Dynamic
Other language versions/interfaces/configuration available on request		

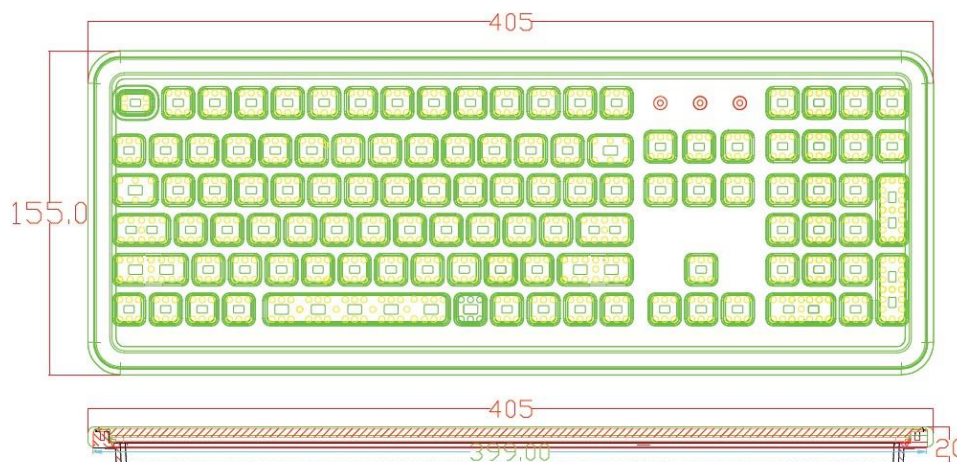



## PRI-KYB-M379-OTBM-NKP-FNK-OEM

**DESCRIPTION:** 120 keys IP65 dynamic rated ruggedized industrial silicone rubber Hygienic keyboard with full keyboard functionalities, integrated numeric keypad and 24 FN keys (F1, F2...F11, F12...F23, F24), sealed & ruggedized IP68 dynamic 25.0mm optical trackball module with 800 DPI resolution for fast and accurate cursor position, industrial PCB with carbon-on-gold key switch technology with long stroke (1.50mm) with extremely good tactile feeling for fast and accurate data input without any noise, with durable coating & antimicrobial keyboard surface withstand to most chemicals and liquids under harsh environment, Clean key for easy cleaning, top panel mounted solutions, adjustable industrial backlight optional. Military level optional



- **Number of Keys:** 120
- **Clean key**
  - Prevents data from being sent while the keyboard is wiped down, allowing user to clean at any interval with minimal downtime
  - User is notified of 'lock down mode' by brightly lit CLEAN KEY
- **G.W.:** 1.20 kgs
- **Dimensions:** 379.00mm x 169.00mm (L x W)

Product Name			IP Rate
PRI-KYB-M379-OTBM-NKP-FNK -OEM	Keyboard; IP68 dynamic optical trackball with 800 DPI resolution; Numeric Keypad, Function keys;	PS/2;USB	IP68 Dynamic
Other language versions/interfaces/configuration available on request			

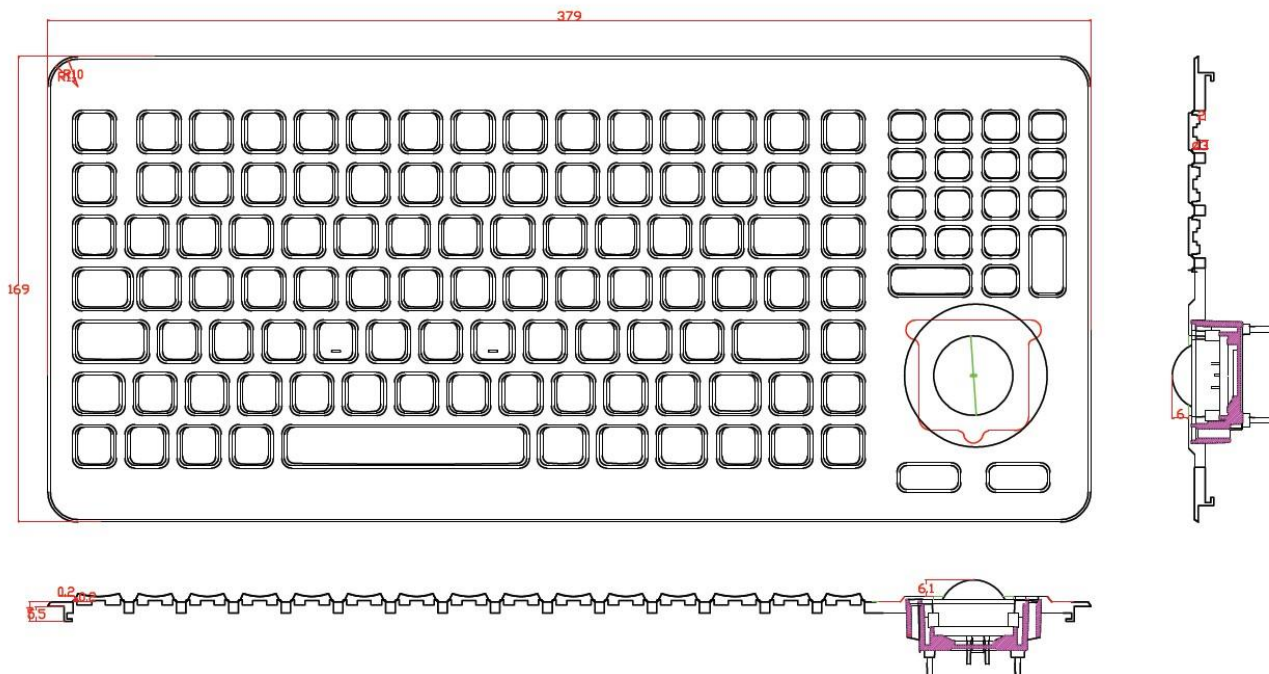

## PRI-KYB-M379-OTBM-NKP-FNK-IL

**DESCRIPTION:** 120 keys IP65 dynamic rated ruggedized industrial silicone rubber Hygienic keyboard with full keyboard functionalities, integrated numeric keypad and 24 FN keys (F1, F2...F11, F12...F23, F24), sealed & ruggedized IP68 dynamic 25.0mm optical trackball module with 800 DPI resolution for fast and accurate cursor position, industrial PCB with carbon-on-gold key switch technology with long stroke (1.50mm) with extremely good tactile feeling for fast and accurate data input without any noise, with durable coating & antimicrobial keyboard surface withstand to most chemicals and liquids under harsh environment, Clean key for easy cleaning, top panel mounted solutions with ruggedized robust poly carbonate frame with mounting studs, adjustable industrial backlight optional. Military level optional.



- **Number of Keys:** 120
- **Clean key**
  - Prevents data from being sent while the keyboard is wiped down, allowing user to clean at any interval with minimal downtime
  - User is notified of 'lock down mode' by brightly lit CLEAN KEY
- **G.W.:** 1.30 kgs
- **Dimensions:** 379.0mm x 169.0mm( L x W)

Product Name		IP Rate	
PRI-KYB-M379-OTBM-NKP -FNK	Keyboard; IP68 dynamic optical trackball with 800 DPI resolution; Numeric Keypad, Function keys	PS/2;USB	IP68 Dynamic
Other language versions/interfaces/configuration available on request			

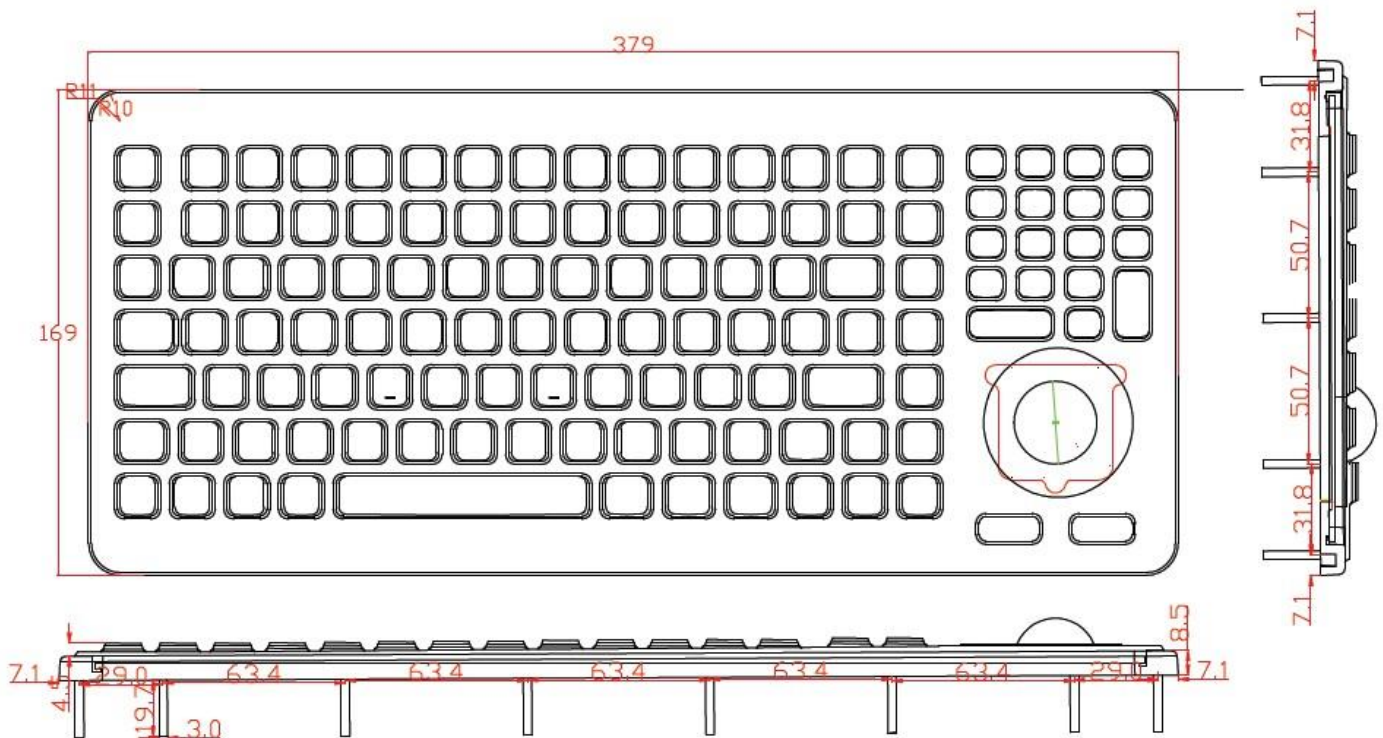

## PRI-KYB-M379RTP-NKP-FNK-OEM

**DESCRIPTION:** 120 keys IP65 dynamic rated & ruggedized industrial silicone rubber Hygienic keyboard with full keyboard functionalities, integrated numeric keypad and 24 FN keys (F1, F2...F11, F12...F23, F24) on upper line, sealed & ruggedized tough touchpad for fast and accurate input, industrial PCB with carbon-on-gold key switch technology with long stroke (1.50mm) with extremely good tactile feeling for fast and accurate data input without any noise, with durable coating & antimicrobial keyboard surface withstand to most chemicals and liquids under harsh environment, Clean key for easy cleaning, top panel mounted solutions, adjustable industrial backlight optional. Military level optional.



- **Number of Keys:** 120
- **Clean key**
  - Prevents data from being sent while the keyboard is wiped down, allowing user to clean at any interval with minimal downtime
  - User is notified of 'lock down mode' by brightly lit CLEAN KEY
- **G.W.:** 0.80 kgs
- **Dimensions:** 379.00mm x 167.00mm ( L x W )

Product Name		IP Rate
PRI-KYB-M379RTP-NKP-FN K-OEM	Keyboard; Numeric Keypad; Touchpad; Function keys	IP65 Dynamic
		PS/2;USB
Other language versions/interfaces/configuration available on request		

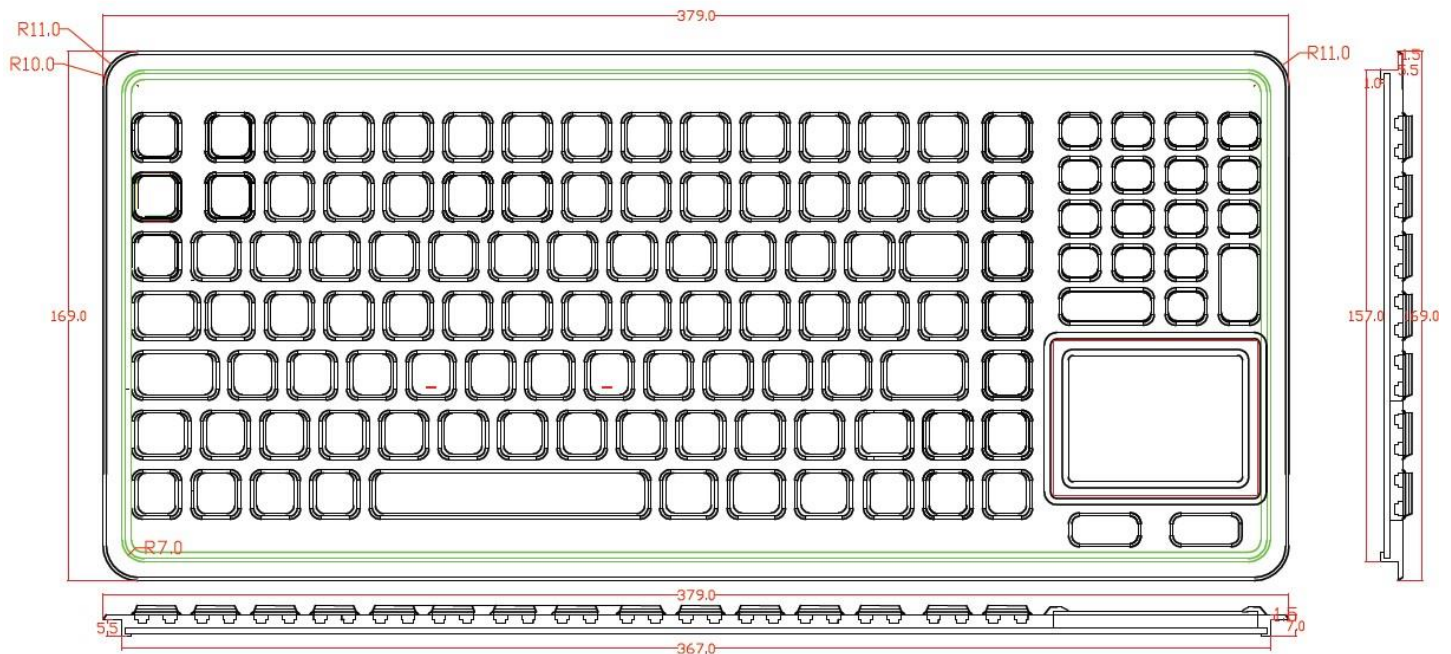



## PRI-KYB-M379RTP-NKP-FNK

**DESCRIPTION:** 120 keys IP65 dynamic rated & ruggedized industrial silicone rubber Hygienic keyboard with full keyboard functionalities with 120 keys, integrated numeric keypad and 24 FN keys (F1, F2...F11, F12...F23, F24), sealed & ruggedized tough touchpad, function keys, with industrial PCB with carbon-on-gold key switch technology with long stroke (1.50mm) with extremely good tactile feeling for fast and accurate data input without any noise, with durable coating & antimicrobial keyboard surface withstand to most chemicals and liquids under harsh environment, Clean key for easy cleaning, top panel mounted solutions with ruggedized robust polycarbonate frame with mounting studs, adjustable industrial backlight optional. Military level optional.



- **Number of Keys:** 120
- **Clean key**
  - Prevents data from being sent while the keyboard is wiped down, allowing user to clean at any interval with minimal downtime
  - User is notified of 'lock down mode' by brightly lit CLEAN KEY
- **G.W.:** 1.00 kgs
- **Dimensions:** 389.3.0mm x 179.2.0mm(L x W )

Product Name			IP Rate
PRI-KYB-M379RTP-NKP-FNK	Keyboard; Numeric Keypad; Touchpad; Function keys	PS/2;USB	IP65 Dynamic
Other language versions/interfaces/configuration available on request			

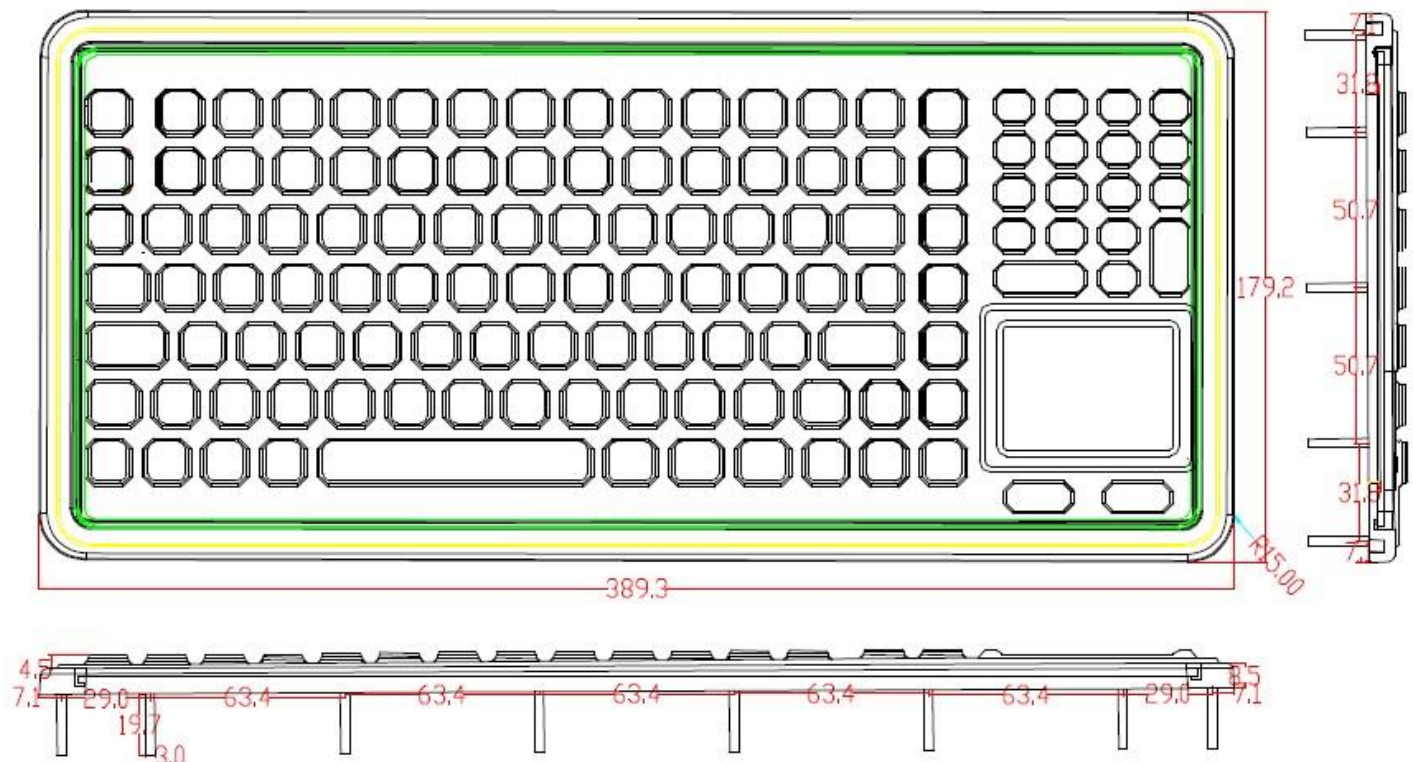



## PRI-KYB-M379RTP-NKP-FNK-BLT-IL-OEM

**DESCRIPTION:** 120 keys IP65 dynamic rated & ruggedized industrial silicone rubber Hygienic keyboard with full keyboard functionalities, integrated numeric keypad and 24 FN keys (F1, F2...F11, F12...F23, F24) on upper line, sealed & ruggedized tough touchpad for fast and accurate input, industrial PCB with carbon-on-gold key switch technology with long stroke (1.50mm) with extremely good tactile feeling for fast and accurate data input without any noise, with durable coating & antimicrobial keyboard surface withstand to most chemicals and liquids under harsh environment, Clean key for easy cleaning via lock/disable the keyboard without needing to take away the keyboard from PC, top panel mounted solutions, adjustable backlight Included, Industrial Level.

**DIMENSIONS:** 379.0mm x 169.0mm(L x W )

### APPLICATIONS:

This keyboard provides full-size versatility in a rugged, compact design with the added convenience of an integrated touchpad. For working in low-light areas, it is with LED backlighting. Engineered for NEMA 4X protection from dust, water and corrosive liquids. This keyboard is ideal for use in environments ranging from manufacturing to material handling to medical settings. Its large numeric pad allows for easy data entry, while its robust polycarbonate case protects it against any hazardous environment.

**MEDICAL:** lab, hospital, clinic, dental, such as carts, diagnostic equipments, operation rooms, dialysis centers etc;

**MATERIAL HANDLING:** mobile keyboard, data entry, assembly line etc

**MILITARY:** Army, Navy, Air force

**INDUSTRIAL:** Industrial automation, pharmaceutical, oil and gas, food and beverage, clean or dirty manufacturing environments, warehouses

**OTHER INDUSTRIES**

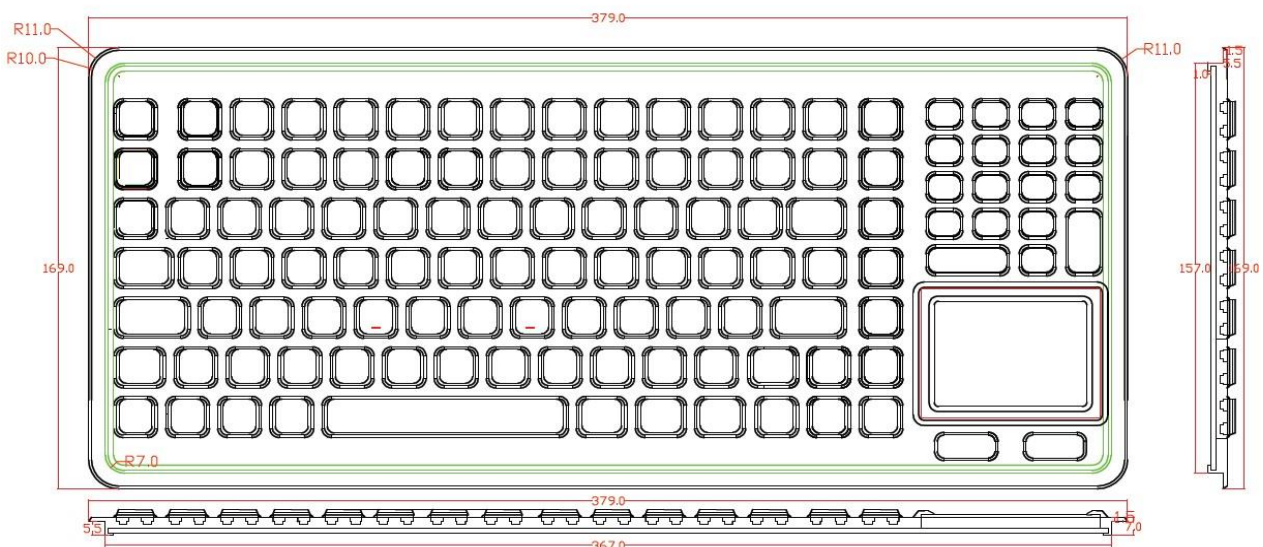

## PRI-KYB-M379RTP-NKP-FNK-BLT-ML-OEM

**DESCRIPTION:** 120 keys IP65 dynamic rated & ruggedized industrial silicone rubber Hygienic keyboard with full keyboard functionalities, integrated numeric keypad and 24 FN keys (F1, F2...F11, F12...F23, F24) on upper line, sealed & ruggedized tough touchpad for fast and accurate input, industrial PCB with carbon-on-gold key switch technology with long stroke (1.50mm) with extremely good tactile feeling for fast and accurate data input without any noise, with durable coating & antimicrobial keyboard surface withstand to most chemicals and liquids under harsh environment, Clean key for easy cleaning via lock/disable the keyboard without needing to take away the keyboard from PC, top panel mounted solutions, adjustable backlight Included. Military level.

**DIMENSIONS:** 379.0mm x 169.0mm (L x W)

### APPLICATIONS:

This keyboard provides full-size versatility in a rugged, compact design with the added convenience of an integrated touchpad. For working in low-light areas, it is with LED backlighting. Engineered for NEMA 4X protection from dust, water and corrosive liquids. This keyboard is ideal for use in environments ranging from manufacturing to material handling to medical settings. Its large numeric pad allows for easy data entry, while its robust polycarbonate case protects it against any hazardous environment.

**MEDICAL:** lab, hospital, clinic, dental, such as carts, diagnostic equipments, operation rooms, dialysis centers etc;

**MATERIAL HANDLING:** mobile keyboard, data entry, assembly line etc

**MILITARY:** Army, Navy, Air force

**INDUSTRIAL:** Industrial automation, pharmaceutical, oil and gas, food and beverage, clean or dirty manufacturing environments, warehouses

**OTHER INDUSTRIES**

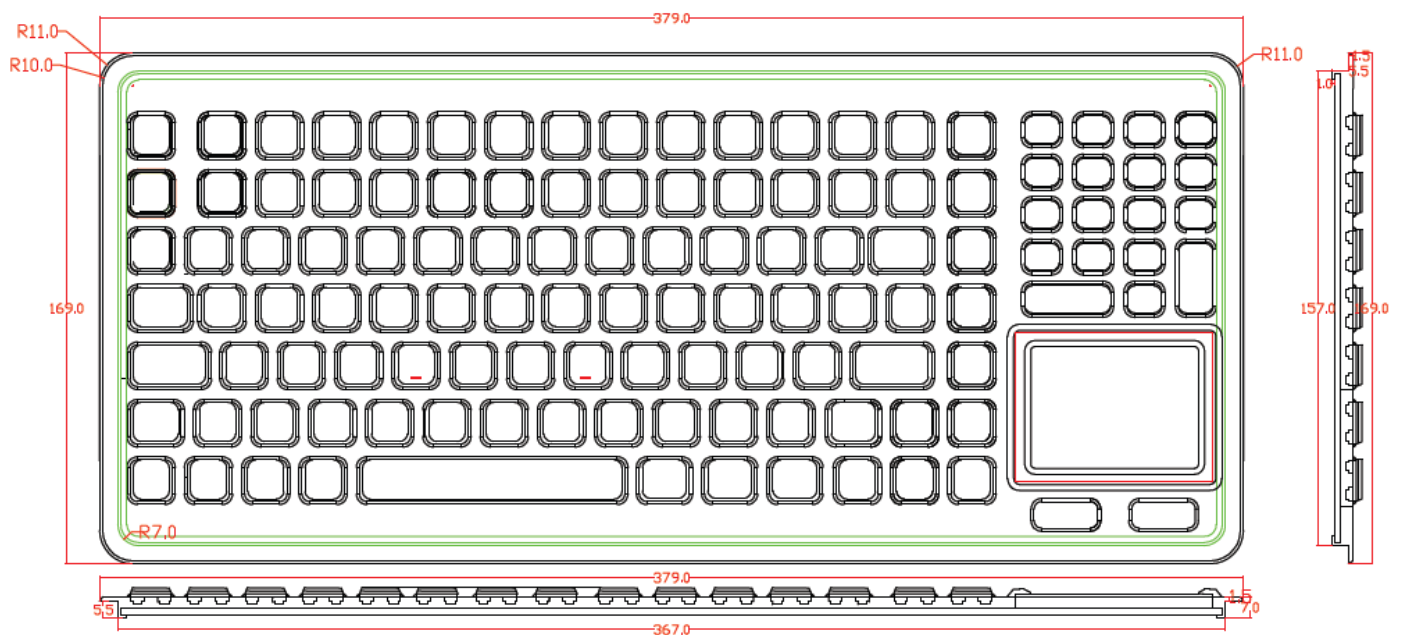

## PRI-KYB-M379-OTBM-NKP-FNK-BLT-IL-OEM

**DESCRIPTION:** 120 keys IP65 dynamic rated ruggedized industrial silicone rubber Hygienic keyboard with full keyboard functionalities, integrated numeric keypad and 24 FN keys (F1, F2...F11, F12...F23, F24), sealed & ruggedized IP68 dynamic 25.0mm optical trackball module with 800 DPI resolution for fast and accurate cursor position, industrial PCB with carbon-on-gold key switch technology with long stroke (1.50mm) with extremely good tactile feeling for fast and accurate data input without any noise, with durable coating & antimicrobial keyboard surface withstand to most chemicals and liquids under harsh environment, Clean key for easy cleaning, top panel mounted solutions, adjustable industrial backlight included, industrial level.

**DIMENSIONS:** 379.0mm x 169.0mm(L x W )

### APPLICATIONS:

This keyboard provides full-size versatility in a rugged, compact design with the added convenience of a trackball. For working in low-light areas, it is with industrial LED backlighting. Engineered for NEMA 4X protection from dust, water and corrosive liquids. This keyboard is ideal for use in environments ranging from manufacturing to material handling to medical settings. Its large numeric pad allows for easy data entry, while its robust polycarbonate case protects it against any hazardous environment.

**MEDICAL:** lab, hospital, clinic, dental, such as carts, diagnostic equipments, operation rooms, dialysis centers etc;

**MATERIAL HANDLING:** mobile keyboard, data entry, assembly line etc

**MILITARY:** Army, Navy, Air force

**INDUSTRIAL:** Industrial automation, pharmaceutical, oil and gas, food and beverage, clean or dirty manufacturing environments, warehouses.

**OTHER INDUSTRIES**

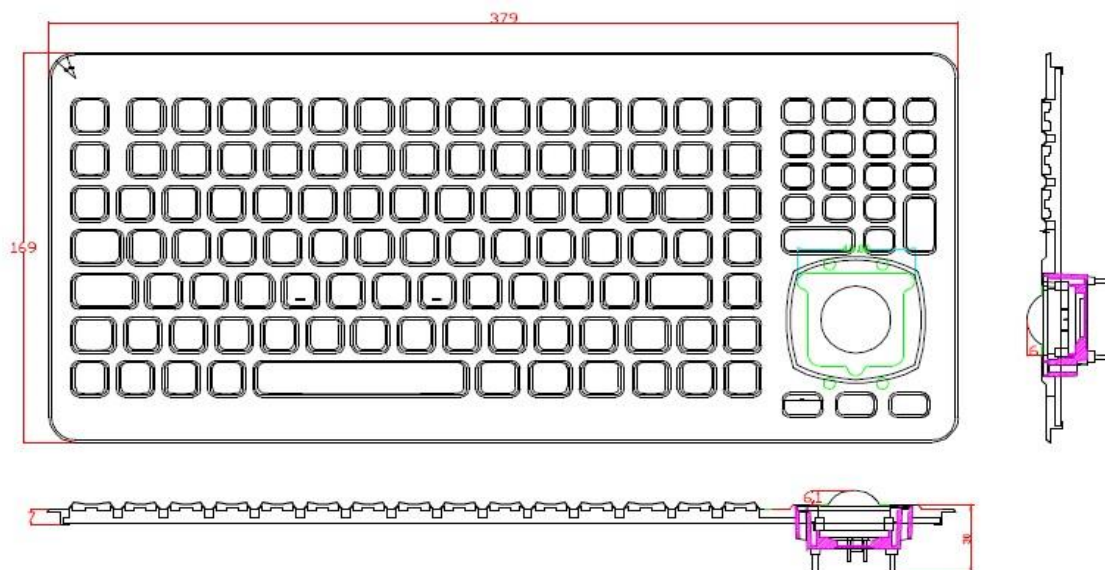



## PRI-KYB-M379-OTBM-NKP-FNK-BLT-IL

**DESCRIPTION:** 120 keys IP65 dynamic rated ruggedized industrial silicone rubber Hygienic keyboard with full keyboard functionalities, integrated numeric keypad and 24 FN keys (F1, F2...F11, F12...F23, F24), sealed & ruggedized IP68 dynamic 25.0mm optical trackball module with 800 DPI resolution for fast and accurate cursor position, industrial PCB with carbon-on-gold key switch technology with long stroke (1.50mm) with extremely good tactile feeling for fast and accurate data input without any noise, with durable coating & antimicrobial keyboard surface withstand to most chemicals and liquids under harsh environment, Clean key for easy cleaning, top panel mounted solutions with sealed & ruggedized robust polycarbonate frame with mounting studs, adjustable industrial backlight included, industrial level.

**DIMENSIONS:** 379.0mm x 169.0mm(L x W )

### APPLICATIONS:

This keyboard provides full-size versatility in a rugged, compact design with the added convenience of a trackball. For working in low-light areas, it is with industrial LED backlighting. Engineered for NEMA 4X protection from dust, water and corrosive liquids. This keyboard is ideal for use in environments ranging from manufacturing to material handling to medical settings. Its large numeric pad allows for easy data entry, while its robust polycarbonate case protects it against any hazardous environment.

**MEDICAL:** lab, hospital, clinic, dental, such as carts, diagnostic equipments, operation rooms, dialysis centers etc;

**MATERIAL HANDLING:** mobile keyboard, data entry, assembly line etc

**MILITARY:** Army, Navy, Air force

**INDUSTRIAL:** Industrial automation, pharmaceutical, oil and gas, food and beverage, clean or dirty manufacturing environments, warehouses.

**OTHER INDUSTRIES**

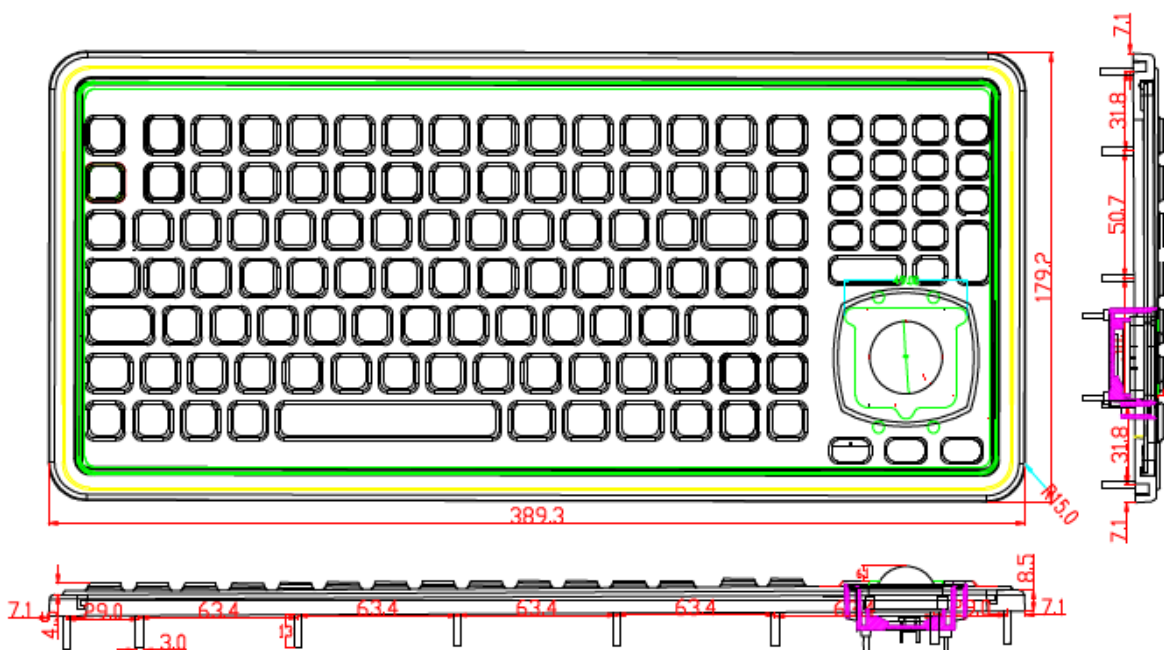



## PRI-KYB-M379-OTBM-NKP-FNK-SLS-IL

**DESCRIPTION:** 120 keys IP65 dynamic rated ruggedized industrial silicone rubber Hygienic keyboard with full keyboard functionalities, integrated numeric keypad and 24 FN keys (F1, F2...F11, F12...F23, F24), sealed & ruggedized IP68 dynamic 25.0mm optical trackball module with 800 DPI resolution for fast and accurate cursor position, industrial PCB with carbon-on-gold key switch technology with long stroke (1.50mm) with extremely good tactile feeling for fast and accurate data input without any noise, with durable coating & antimicrobial keyboard surface withstand to most chemicals and liquids under harsh environment, Clean key for easy cleaning, top panel mounted solutions with ruggedized robust polycarbonate frame with mounting studs, top panel mounted with stainless steel back plate sealed with top ruggedized industrial silicone cover & industrial PCB for ruggedized structure and easy mounting and sealing, stainless steel housing protects the electronics controller. Adjustable industrial backlight optional, industrial level.

**DIMENSIONS:** 389.3.0mm x 179.2.0mm(L x W )

### APPLICATIONS:

This keyboard provides full-size versatility in a rugged, compact design with the added convenience of a trackball. For working in low-light areas, it is also available with optional LED backlighting. Engineered for NEMA 4X protection from dust, water and corrosive liquids. This keyboard is ideal for use in environments ranging from manufacturing to material handling to medical settings. Its large numeric pad allows for easy data entry, while its robust polycarbonate case protects it against any hazardous environment.

**MEDICAL:** lab, hospital, clinic, dental, such as carts, diagnostic equipments, operation rooms, dialysis centers etc;

**MATERIAL HANDLING:** mobile keyboard, data entry, assembly line etc

**MILITARY:** Army, Navy, Air force

**INDUSTRIAL:** Industrial automation, pharmaceutical, oil and gas, food and beverage, clean or dirty manufacturing environments, warehouses

**OTHER INDUSTRIES**



## PRI-KYB-M379-OTBM-NKP-FNK-BLT-SLS-IL

**DESCRIPTION:** 120 keys IP65 dynamic rated ruggedized industrial silicone rubber Hygienic keyboard with full keyboard functionalities, integrated numeric keypad and 24 FN keys (F1, F2...F11, F12...F23, F24), sealed & ruggedized IP68 dynamic 25.0mm optical trackball module with 800 DPI resolution for fast and accurate cursor position, industrial PCB with carbon-on-gold key switch technology with long stroke (1.50mm) with extremely good tactile feeling for fast and accurate data input without any noise, with durable coating & antimicrobial keyboard surface withstand to most chemicals and liquids under harsh environment, Clean key for easy cleaning, top panel mounted solutions with ruggedized robust polycarbonate frame with mounting studs, top panel mounted with stainless steel back plate sealed with top ruggedized industrial silicone cover & military PCB for ruggedized structure and easy mounting and sealing, stainless steel housing protects the electronics controller, adjustable industrial backlight included, industrial level.

**DIMENSIONS:** 379.0mm x 169.0mm(L x W )

### APPLICATIONS:

This keyboard provides full-size versatility in a rugged, compact design with the added convenience of a trackball. For working in low-light areas, it is with industrial LED backlighting. Engineered for NEMA 4X protection from dust, water and corrosive liquids. This keyboard is ideal for use in environments ranging from manufacturing to material handling to medical settings. Its large numeric pad allows for easy data entry, while its robust polycarbonate case protects it against any hazardous environment.

**MEDICAL:** lab, hospital, clinic, dental, such as carts, diagnostic equipments, operation rooms, dialysis centers etc;

**MATERIAL HANDLING:** mobile keyboard, data entry, assembly line etc

**MILITARY:** Army, Navy, Air force

**INDUSTRIAL:** Industrial automation, pharmaceutical, oil and gas, food and beverage, clean or dirty manufacturing environments, warehouses.

**OTHER INDUSTRIES**

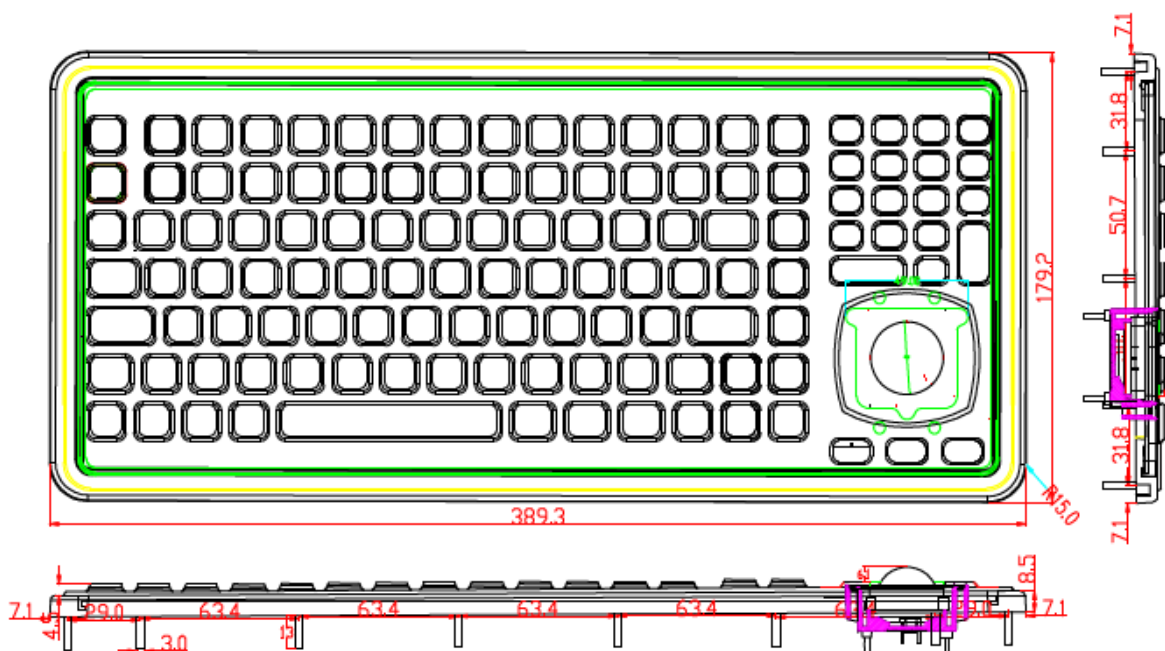

## PRI-KYB-M379RTP-NKP-FNK-BLT-IL

**DESCRIPTION:** 120 keys IP65 dynamic rated & ruggedized industrial silicone rubber Hygienic keyboard with full keyboard functionalities with 120 keys, integrated numeric keypad and 24 FN keys (F1, F2...F11, F12...F23, F24), sealed & ruggedized tough touchpad, function keys, with industrial PCB with carbon-on-gold key switch technology with long stroke (1.50mm) with extremely good tactile feeling for fast and accurate data input without any noise, with durable coating & antimicrobial keyboard surface withstand to most chemicals and liquids under harsh environment, Clean key for easy cleaning via lock/disable the keyboard without needing to take away the keyboard from PC, top panel mounted solutions with sealed & ruggedized robust polycarbonate frame with mounting studs, adjustable industrial backlight included, Industrial level.

**DIMENSIONS:** 379.0mm x 169.0mm (L x W)

### APPLICATIONS:

This keyboard provides full-size versatility in a rugged, compact design with the added convenience of an integrated touchpad. For working in low-light areas, it is with LED backlighting. Engineered for NEMA 4X protection from dust, water and corrosive liquids. This keyboard is ideal for use in environments ranging from manufacturing to material handling to medical settings. Its large numeric pad allows for easy data entry, while its robust polycarbonate case protects it against any hazardous environment.

**MEDICAL:** lab, hospital, clinic, dental, such as carts, diagnostic equipments, operation rooms, dialysis centers etc;

**MATERIAL HANDLING:** mobile keyboard, data entry, assembly line etc

**MILITARY:** Army, Navy, Air force

**INDUSTRIAL:** Industrial automation, pharmaceutical, oil and gas, food and beverage, clean or dirty manufacturing environments, warehouses

**OTHER INDUSTRIES**

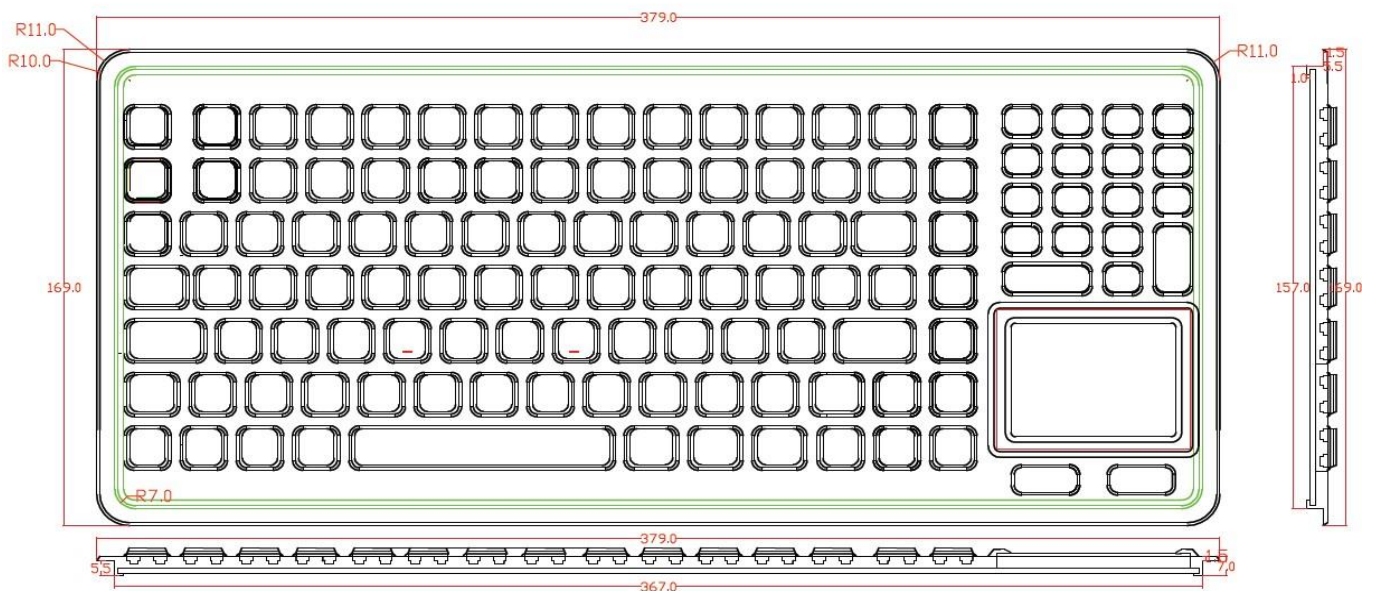







## PRI-KYB-M379RTP-NKP-FNK-BLT-SLS-IL

**DESCRIPTION:** 120 keys IP65 dynamic rated & ruggedized industrial silicone rubber Hygienic keyboard with full keyboard functionalities with 120 keys, integrated numeric keypad and 24 FN keys (F1, F2...F11, F12...F23, F24), sealed & ruggedized tough touchpad, function keys, with industrial PCB with carbon-on-gold key switch technology with long stroke (1.50mm) with extremely good tactile feeling for fast and accurate data input without any noise, with durable coating & antimicrobial keyboard surface withstand to most chemicals and liquids under harsh environment, Clean key for easy cleaning via lock/disable the keyboard without needing to take away the keyboard from PC, top panel mounted solutions with ruggedized robust polycarbonate frame with mounting studs, top panel mounted with stainless steel back plate sealed with top ruggedized industrial silicone cover & industrial PCB for ruggedized structure and easy mounting and sealing, stainless steel housing shielded and protected the industrial electronics controller, adjustable industrial backlight included, Industrial level.

**DIMENSIONS:** 379.0mm x 169.0mm(L x W )

### APPLICATIONS:

This keyboard provides full-size versatility in a rugged, compact design with the added convenience of an integrated touchpad. For working in low-light areas, it is with LED backlighting. Engineered for NEMA 4X protection from dust, water and corrosive liquids. This keyboard is ideal for use in environments ranging from manufacturing to material handling to medical settings. Its large numeric pad allows for easy data entry, while its stainless steel housing shielded protects it against any hazardous environment.

**MEDICAL:** lab, hospital, clinic, dental, such as carts, diagnostic equipments, operation rooms, dialysis centers etc;

**MATERIAL HANDLING:** mobile keyboard, data entry, assembly line etc

**MILITARY:** Army, Navy, Air force

**INDUSTRIAL:** Industrial automation, pharmaceutical, oil and gas, food and beverage, clean or dirty manufacturing environments, warehouses

**OTHER INDUSTRIES**

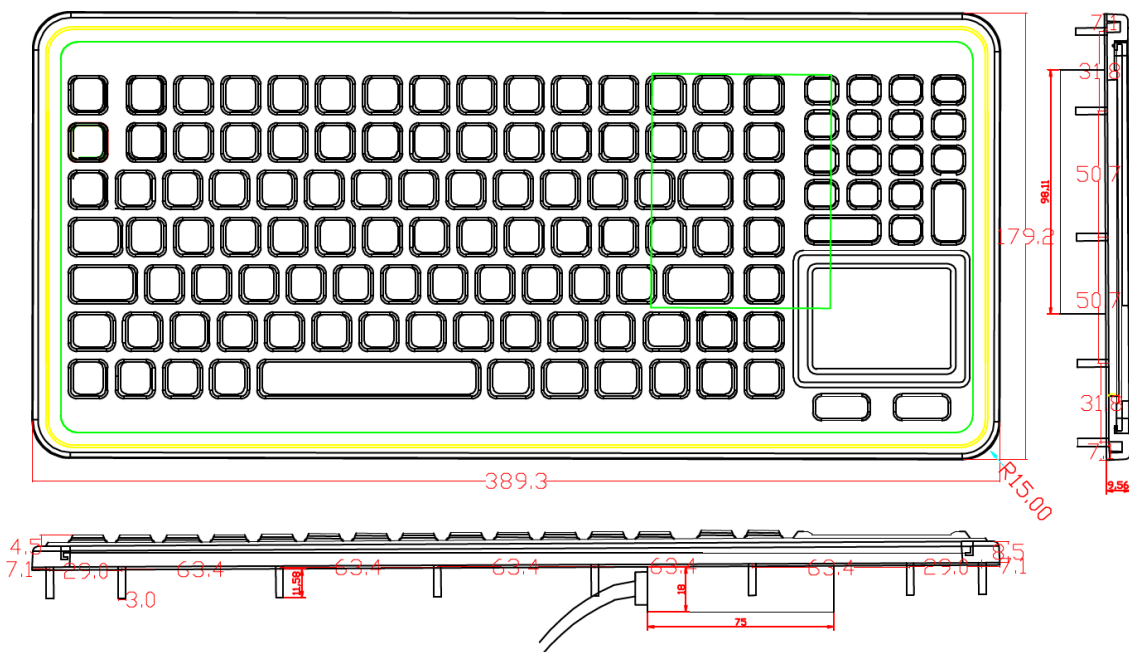



## PRI-KYB-M390RTP-NKP-FNK-MDT

**DESCRIPTION:** 108 keys IP68 dynamic rated & ruggedized industrial silicone rubber Hygienic keyboard with full keyboard functionalities, integrated numeric keypad, sealed & ruggedized tough touchpad for fast and accurate cursor position, function keys (F1, F2...F11, F12) are on upper line; with industrial PCB with carbon-on-gold key switch technology with long stroke (1.50mm) with extremely good tactile feeling for fast and accurate data input without any noise, with durable coating & antimicrobial keyboard surface withstand to most chemicals and liquids under harsh environment, Clean key for easy cleaning via lock/disable the keyboard without needing to take the keyboard from PC, movable stand alone desk top version sealed & ruggedized with 5.0mm thickness aluminum back plate with sand blasting & oxygenation surface treatment, adjustable industrial backlight optional.

### APPLICATIONS:

This keyboard provides full-size versatility in a rugged, compact design with the added convenience of an integrated numeric keypad. For working in low-light areas, it is also available with optional LED backlighting. Engineered for NEMA 4X protection from dust, water and corrosive liquids. This keyboard is ideal for use in environments ranging from manufacturing to material handling to medical settings. Its numeric pad allows for easy data entry.

- **MEDICAL:** lab, hospital, clinic, dental, such as carts, diagnostic equipments, operation rooms, dialysis centers etc;
- **MATERIAL HANDLING:** mobile keyboard, data entry, assembly line etc
- **MILITARY:** Army, Navy, Air force
- **INDUSTRIAL:** Industrial automation, pharmaceutical, oil and gas, food and beverage, clean or dirty manufacturing environments, warehouses
- **OTHER INDUSTRIES**



- **Number of Keys:** 108
- **Clean key**  
-Prevents data from being sent while the keyboard is wiped down, allowing user to clean at any interval with minimal downtime  
-User is notified of 'lock down mode' by brightly lit CLEAN KEY
- Enclosure: industrial silicone, Aluminum (rear side).
- **G.W.:** 1.50 kgs
- **Dimensions:** 390.0mm x 159.0mm x 19.0mm(L x W x H)

Product Name		IP Rate	
PRI-KYB-M390RTP-NKP-FNK-MDT	Keyboard; Touchpad; Numeric Keypad; Function keys; Desk top keyboard	PS/2;USB	IP68 Dynamic
Other language versions/interfaces/configuration available on request			

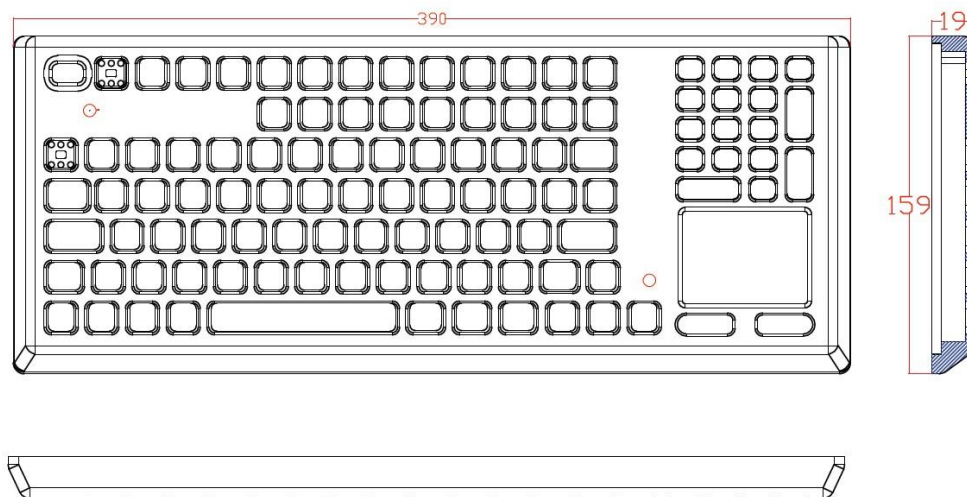

## PRI-KYB-M396RTP-NKP-FNK-MDT

**DESCRIPTION:** 106 keys IP68 dynamic sealed & ruggedized industrial silicone rubber Hygienic keyboard with full keyboard functionalities, integrated numeric keypad, function keys, sealed & ruggedized tough touchpad for fast and accurate cursor position, industrial PCB with carbon-on-gold key switch technology with long stroke (1.50mm) with extremely good tactile feeling for fast and accurate data input without any noise, with durable coating & antimicrobial keyboard surface withstand to most chemicals and liquids under harsh environment, CLEAN key for easy cleaning via lock/disable the keyboard without needing to take away the keyboard from PC, mountable desk top version with robust polycarbonate case. Adjustable industrial backlight optional, military level optional.

### APPLICATIONS:

This keyboard provides full-size versatility in a rugged, compact design with the added convenience of an integrated touchpad. For working in low-light areas, it is also available with optional LED backlighting. Engineered for NEMA 4X protection from dust, water and corrosive liquids. This keyboard is ideal for use in environments ranging from manufacturing to material handling to medical settings. Its large numeric pad allows for easy data entry, while its robust polycarbonate case protects it against any hazardous environment.

- **MEDICAL:** lab, hospital, clinic, dental, such as carts, diagnostic equipments, operation rooms, dialysis centers etc;
- **MATERIAL HANDLING:** mobile keyboard, data entry, assembly line etc
- **MILITARY:** Army, Navy, Air force
- **INDUSTRIAL:** Industrial automation, pharmaceutical, oil and gas, food and beverage, clean or dirty manufacturing environments, warehouses



- **Number of Keys:** 106
- **OTHER INDUSTRIES**
  - Prevents data from being sent while the keyboard is wiped down, allowing user to clean at any interval with minimal downtime
  - User is notified of 'lock down mode' by brightly lit CLEAN KEY
- Enclosure: industrial silicone, Aluminum (rear side).
- **G.W.:** 1.30 kgs
- **Dimensions:** 396.0mm x 149.3mm x 20.1mm (L x W x H)

Product Name			IP Rate
PRI-KYB-M396RTP-NKP-FNK-MDT	Keyboard; Touchpad; Numeric Keypad; Function keys; Mounting Desk top keyboard	PS/2;USB	IP68 Dynamic
Other language versions/interfaces/configuration available on request			

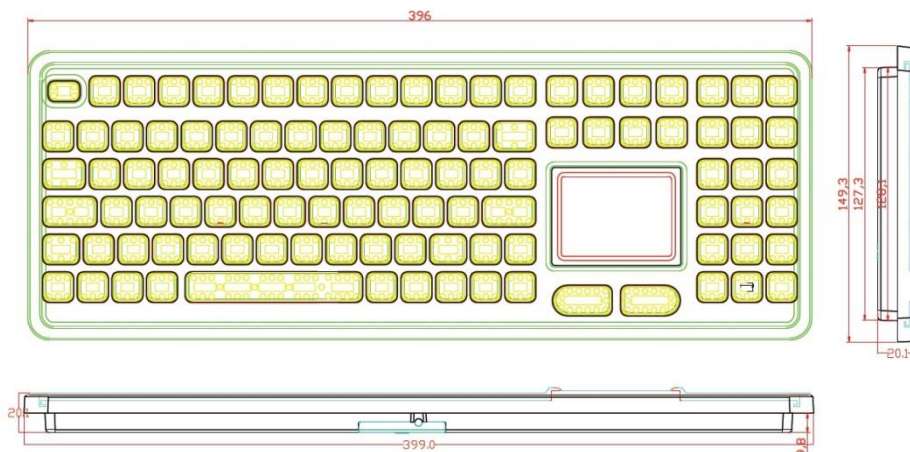



## PRI-KYB-M396-OTBM-NKP-FNK-MDT

**DESCRIPTION:** 106 keys IP68 dynamic sealed & ruggedized industrial silicone rubber Hygienic keyboard with full keyboard functionalities function keys, integrated numeric keypad, IP68 dynamic rated 16.0mm optical trackball module with 800 DPI resolutions for fast and accurate cursor position with extremely smooth operation, industrial PCB with carbon-on-gold key switch technology with long stroke (1.50mm) with extremely good tactile feeling for fast and accurate data input without any noise, with durable coating & antimicrobial keyboard surface withstand to most chemicals and liquids under harsh environment, Clean key for easy cleaning, mountable desk top version with robust polycarbonate case, adjustable industrial backlight optional.

### APPLICATIONS:

**MEDICAL:** lab, hospital, clinic, dental, such as carts, diagnostic equipments, operation rooms, dialysis centers etc

**MATERIAL HANDLING:** mobile keyboard, data entry, assembly line etc

**MILITARY:** Army, Navy, Air force

**INDUSTRIAL:** Industrial automation, pharmaceutical, oil and gas, food and beverage, clean or dirty manufacturing environments, warehouses



- **Number of Keys:** 106
- **Clean key**
  - Prevents data from being sent while the keyboard is wiped down, allowing user to clean at any interval with minimal downtime
  - User is notified of 'lock down mode' by brightly lit CLEAN KEY
- Enclosure: industrial silicone, Aluminum (rear side).
- **G.W.:** 1.50 kgs
- **Dimensions:** 396.0mm x 149.3mm x 20.1mm (L x W x H)

Product Name			IP Rate
PRI-KYB-M396-OTBM-NKP -FNK-MDT	Keyboard; Trackball; Numeric Keypad; Function keys; Desk top version keyboard	PS/2;USB	IP68 Dynamic
Other language versions/interfaces/configuration available on request			

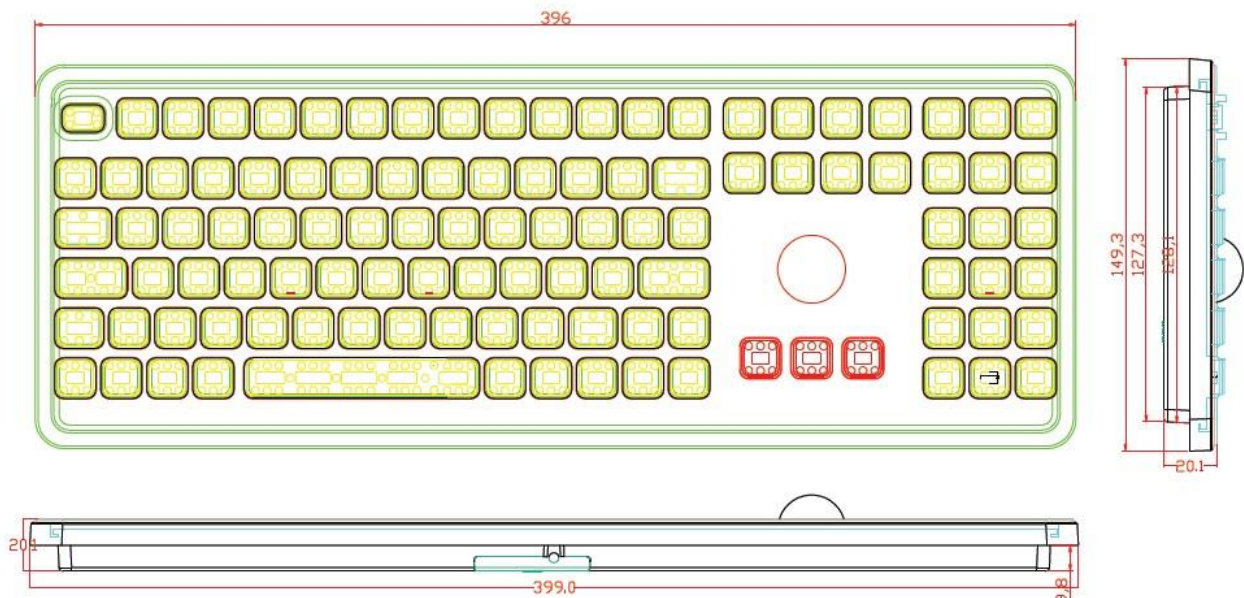

## PRI-KYB-M399NKP-FNK

**DESCRIPTION:** 106 keys IP66 dynamic sealed & ruggedized silicone rubber industrial Hygienic keyboard with industrial PCB electronics included, integrated numeric keypad, function keys (F1, F2...F11, F12) and industrial PCB electronics with carbon-on-gold key switch technology with long stroke (1.50mm) with extremely good tactile feeling for fast and accurate data input without any noise, with durable coating & antimicrobial keyboard surface withstand to most chemicals and liquids under harsh environment, CLEAN key for easy cleaning via lock/disable the keyboard without needing to take away the keyboard from PC, top panel mounted with aluminium back plate sealed with top ruggedized industrial silicone cover & Industrial carbon-on-gold PCB, adjustable industrial backlight optional, military level optional.

**DIMENSIONS :** 399.0mm x 150.0mm (L x W )

### APPLICATIONS:

This keyboard provides full-size versatility in a rugged, compact design with the added convenience of an integrated keypad. For working in low-light areas, it is also available with optional LED backlighting. Engineered for NEMA 4X protection from dust, water and corrosive liquids. This keyboard is ideal for use in environments ranging from manufacturing to material handling to medical settings. Its numeric pad allows for easy data entry.

**MEDICAL:** lab, hospital, clinic, dental, such as carts, diagnostic equipments, operation rooms, dialysis centers etc;

**MATERIAL HANDLING:** mobile keyboard, data entry, assembly line etc

**MILITARY:** Army, Navy, Air force

**INDUSTRIAL:** Industrial automation, pharmaceutical, oil and gas, food and beverage, clean or dirty manufacturing environments, warehouses

**OTHER INDUSTRIES**

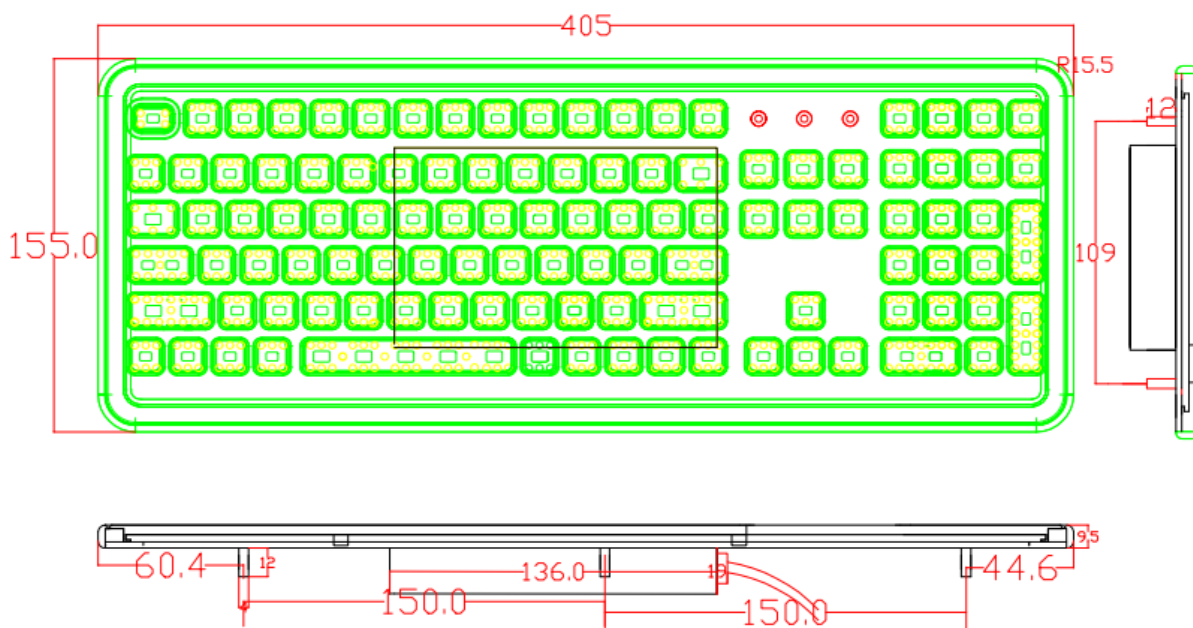

## PRI-KYB-M399NKP-FNK-BLT

**DESCRIPTION:** 106 keys IP66 dynamic sealed & ruggedized silicone rubber industrial Hygienic keyboard with industrial PCB electronics included, integrated numeric keypad, function keys (F1, F2...F11, F12) and industrial PCB electronics with carbon-on-gold key switch technology with long stroke (1.50mm) with extremely good tactile feeling for fast and accurate data input without any noise, with durable coating & antimicrobial keyboard surface withstand to most chemicals and liquids under harsh environment, CLEAN key for easy cleaning via lock/disable the keyboard without needing to take away the keyboard from PC, top panel mounted with aluminium back plate sealed with top ruggedized industrial silicone cover & Industrial carbon-on-gold PCB, adjustable industrial backlight included, military level optional.

**DIMENSIONS :** 399.0mm x 150.0mm (L x W )

### APPLICATIONS:

This keyboard provides full-size versatility in a rugged, compact design with the added convenience of an integrated keypad. For working in low-light areas, it is with LED backlighting. Engineered for NEMA 4X protection from dust, water and corrosive liquids. This keyboard is ideal for use in environments ranging from manufacturing to material handling to medical settings. Its numeric pad allows for easy data entry.

**MEDICAL:** lab, hospital, clinic, dental, such as carts, diagnostic equipments, operation rooms, dialysis centers etc;

**MATERIAL HANDLING:** mobile keyboard, data entry, assembly line etc

**MILITARY:** Army, Navy, Air force

**INDUSTRIAL:** Industrial automation, pharmaceutical, oil and gas, food and beverage, clean or dirty manufacturing environments, warehouses

**OTHER INDUSTRIES**

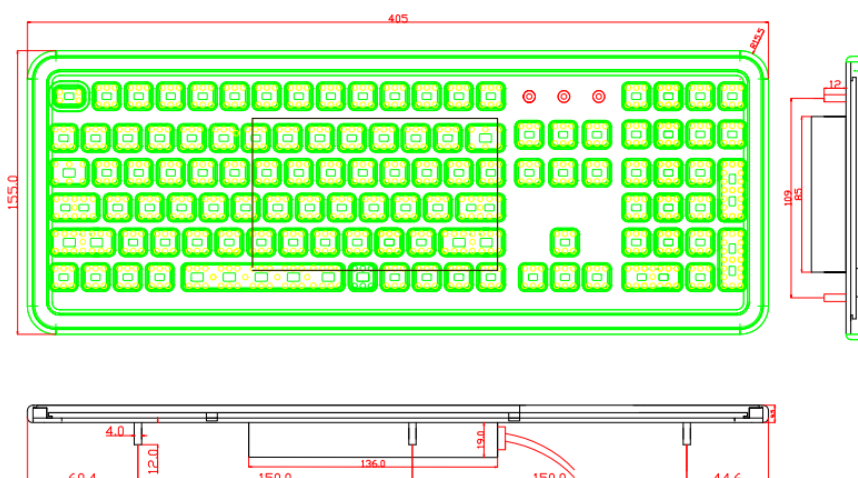



## PRI-KYB-M399NKP-FNK-MDT-BLT

**DESCRIPTION:** 106 keys IP68 dynamic rated ruggedized industrial silicone rubber Hygienic keyboard, with integrated numeric keypad on right side, function keys on upper line, and industrial PCB with carbon-on-gold key switch technology with long stroke (1.50mm) with extremely good tactile feeling for fast and accurate data input without any noise, with durable coating & antimicrobial keyboard surface withstand to most chemicals and liquids under harsh environment, Clean key for easy cleaning via lock/disable the keyboard without needing to take away the keyboard from PC, movable stand alone desk top version with robust polycarbonate case, adjustable industrial backlight included.

**DIMENSIONS:** 399.0mm x 150.0mm x 20.0mm (L x W x H)

### APPLICATIONS:

This keyboard provides full-size versatility in a rugged, compact design with the added convenience of an integrated keypad. For working in low-light areas, it is with LED backlighting. Engineered for NEMA 4X protection from dust, water and corrosive liquids. This keyboard is ideal for use in environments ranging from manufacturing to material handling to medical settings. Its big numeric pad allows for easy data entry.

**MEDICAL:** lab, hospital, clinic, dental, such as carts, diagnostic equipments, operation rooms, dialysis centers etc;

**MATERIAL HANDLING:** mobile keyboard, data entry, assembly line etc

**MILITARY:** Army, Navy, Air force

**INDUSTRIAL:** Industrial automation, pharmaceutical, oil and gas, food and beverage, clean or dirty manufacturing environments, warehouses

**OTHER INDUSTRIES**





## PRI-KYB-M399RTP-NKP-FNK

**DESCRIPTION:** 108 keys IP65 dynamic rated ruggedized industrial silicone rubber Hygienic keyboard with full keyboard functionalities with FN (F1, F2...F11, F12) on upper line, integrated numeric keypad, sealed & ruggedized tough touchpad for fast and accurate cursor position, industrial PCB with carbon-on-gold key switch technology with long stroke (1.50mm) with extremely good tactile feeling for fast and accurate data input without any noise, with durable coating & antimicrobial keyboard surface withstand to most chemicals and liquids under harsh environment, Clean key for easy cleaning via lock/disable the keyboard without needing to take away the keyboard from PC, top panel mounted with 3.0mm oxygenation surface treatment aluminum back plate sealed with top ruggedized industrial silicone cover & Industrial carbon-on-gold PCB, adjustable industrial backlight optional.

**DIMENSIONS:** 399.0mm x 150.0mm (L x W )

### APPLICATIONS:

This keyboard provides full-size versatility in a rugged, compact design with the added convenience of an integrated touchpad. For working in low-light areas, it is also available with optional LED backlighting. Engineered for NEMA 4X protection from dust, water and corrosive liquids. This keyboard is ideal for use in environments ranging from manufacturing to material handling to medical settings. Its large numeric pad allows for easy data entry, while its robust polycarbonate case protects it against any hazardous environment.

**MEDICAL:** lab, hospital, clinic, dental, such as carts, diagnostic equipments, operation rooms, dialysis centers etc;

**MATERIAL HANDLING:** mobile keyboard, data entry, assembly line etc

**MILITARY:** Army, Navy, Air force

**INDUSTRIAL:** Industrial automation, pharmaceutical, oil and gas, food and beverage, clean or dirty manufacturing environments, warehouses

**OTHER INDUSTRIES**

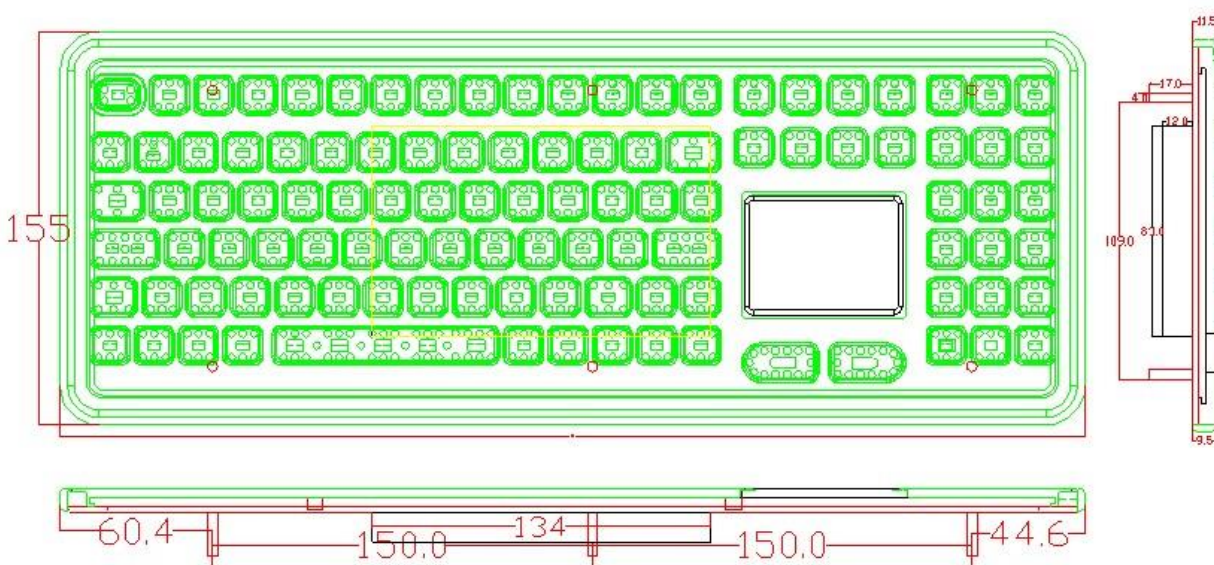

## PRI-KYB-M399RTP-NKP-FNK-BLT

**DESCRIPTION:** 108 keys IP66 dynamic sealed & ruggedized silicone rubber industrial Hygienic keyboard with full keyboard functionalities with FN (F1, F2...F11, F12) on upper line, integrated numeric keypad, sealed & ruggedized tough touchpad for fast and accurate cursor position, industrial PCB with carbon-on-gold key switch technology with long stroke (1.50mm) with extremely good tactile feeling for fast and accurate data input without any noise, with durable coating & antimicrobial keyboard surface withstand to most chemicals and liquids under harsh environment, CLEAN key for easy cleaning keyboard via lock/disable the keyboard without needing to take away the keyboard from PC, top panel mounted with 3.0mm oxygenation surface treatment aluminium back plate sealed with top ruggedized industrial silicone cover & Industrial carbon-on-gold PCB, adjustable industrial backlight included, military helve optional.

**DIMENSIONS:** 399.0mm x 150.0mm (L x W)

### APPLICATIONS:

This keyboard provides full-size versatility in a rugged, compact design with the added convenience of an integrated touchpad. For working in low-light areas, it is with LED backlighting. Engineered for NEMA 4X protection from dust, water and corrosive liquids. This keyboard is ideal for use in environments ranging from manufacturing to material handling to medical settings. Its large numeric pad allows for easy data entry, while its robust polycarbonate case protects it against any hazardous environment.

**MEDICAL:** lab, hospital, clinic, dental, such as carts, diagnostic equipments, operation rooms, dialysis centers etc;

**MATERIAL HANDLING:** mobile keyboard, data entry, assembly line etc

**MILITARY:** Army, Navy, Air force

**INDUSTRIAL:** Industrial automation, pharmaceutical, oil and gas, food and beverage, clean or dirty manufacturing environments, warehouses

**OTHER INDUSTRIES**

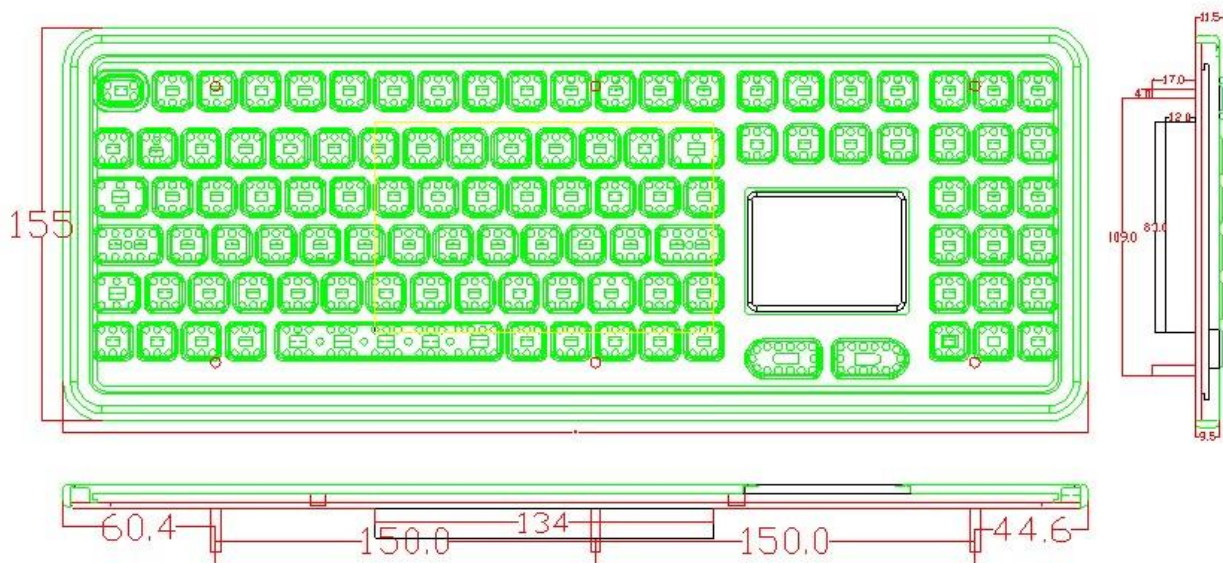

## PRI-KYB-M399RTP-NKP-FNK-MDT-BLT

**DESCRIPTION:** 108 keys IP68 dynamic sealed & ruggedized industrial silicone rubber Hygienic keyboard with full keyboard functionalities with FN (F1, F2...F11, F12) on upper line, integrated numeric keypad, sealed & ruggedized tough touchpad for fast and accurate cursor position, with industrial PCB with carbon-on-gold key switch technology with long stroke (1.50mm) with extremely good tactile feeling for fast and accurate data input without any noise, with durable coating & antimicrobial keyboard surface withstand to most chemicals and liquids under harsh environment, Clean key for easy cleaning via lock/disable the keyboard without needing to take away the keyboard from PC, standard alone desk top version sealed with robust polycarbonate case, adjustable industrial backlight included.

**DIMENSIONS:** 399.0mm x 150.0mm x 20.0mm ( L x W x H )

### APPLICATIONS:

This keyboard provides full-size versatility in a rugged, compact design with the added convenience of an integrated touchpad. For working in low-light areas, it is with LED backlighting. Engineered for NEMA 4X protection from dust, water and corrosive liquids. This keyboard is ideal for use in environments ranging from manufacturing to material handling to medical settings. Its large numeric pad allows for easy data entry, while its robust polycarbonate case protects it against any hazardous environment.

**MEDICAL:** lab, hospital, clinic, dental, such as carts, diagnostic equipments, operation rooms, dialysis centers etc;

**MATERIAL HANDLING:** mobile keyboard, data entry, assembly line etc

**MILITARY:** Army, Navy, Air force

**INDUSTRIAL:** Industrial automation, pharmaceutical, oil and gas, food and beverage, clean or dirty manufacturing environments, warehouses

**OTHER INDUSTRIES**

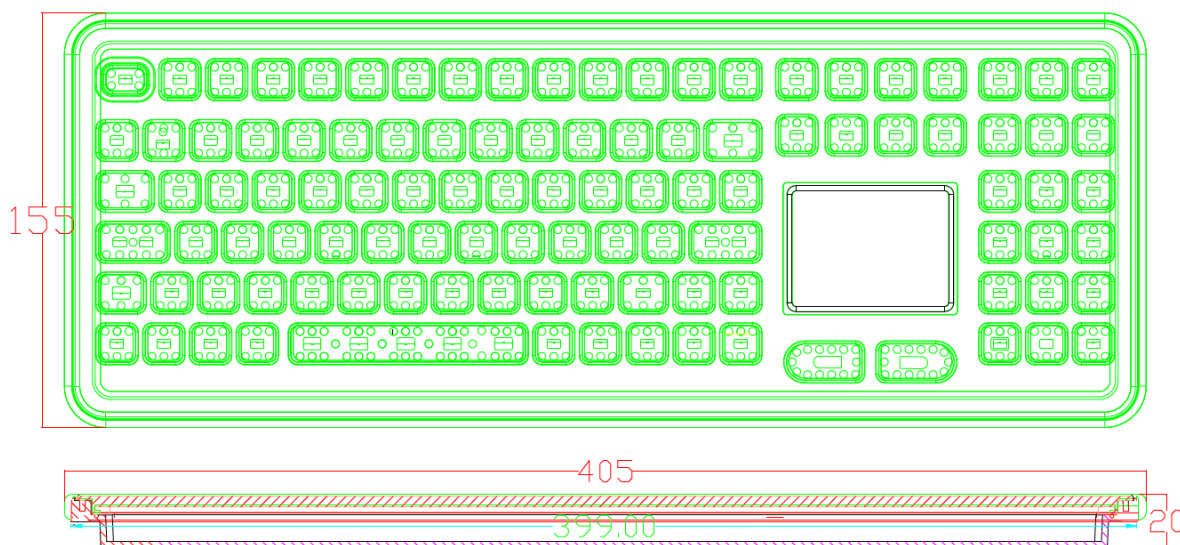



## PRI-KYB-M399RTP-NKP-FNK-MDT

**DESCRIPTION:** 108 keys IP68 dynamic sealed & ruggedized industrial silicone rubber Hygienic keyboard with full keyboard functionalities with FN (F1, F2...F11, F12) on upper line, integrated numeric keypad, sealed & ruggedized tough touchpad for fast and accurate cursor position, with industrial PCB with carbon-on-gold key switch technology with long stroke (1.50mm) with extremely good tactile feeling for fast and accurate data input without any noise, with durable coating & antimicrobial keyboard surface withstand to most chemicals and liquids under harsh environment, Clean key for easy cleaning, standard alone desk top version sealed with robust polycarbonate case, adjustable industrial backlight optional.

### APPLICATIONS:

This keyboard provides full-size versatility in a rugged, compact design with the added convenience of an integrated touchpad. For working in low-light areas, it is also available with optional LED backlighting. Engineered for NEMA 4X protection from dust, water and corrosive liquids. This keyboard is ideal for use in environments ranging from manufacturing to material handling to medical settings. Its large numeric pad allows for easy data entry, while its robust polycarbonate case protects it against any hazardous environment.

- **MEDICAL:** lab, hospital, clinic, dental, such as carts, diagnostic equipments, operation rooms, dialysis centers etc;
- **MATERIAL HANDLING:** mobile keyboard, data entry, assembly line etc
- **MILITARY:** Army, Navy, Air force
- **INDUSTRIAL:** Industrial automation, pharmaceutical, oil and gas, food and beverage, clean or dirty manufacturing environments, warehouses
- **OTHER INDUSTRIES**



- **Number of Keys:** 108
- **Clean key**  
-Prevents data from being sent while the keyboard is wiped down, allowing user to clean at any interval with minimal downtime  
-User is notified of 'lock down mode' by brightly lit CLEAN KEY
- **Enclosure:** industrial silicone, Aluminum (rear side).
- **G.W.:** 1.20 kgs
- **Dimensions:** 399.0mm x 155.0mm x 20.0mm(L x W x H)

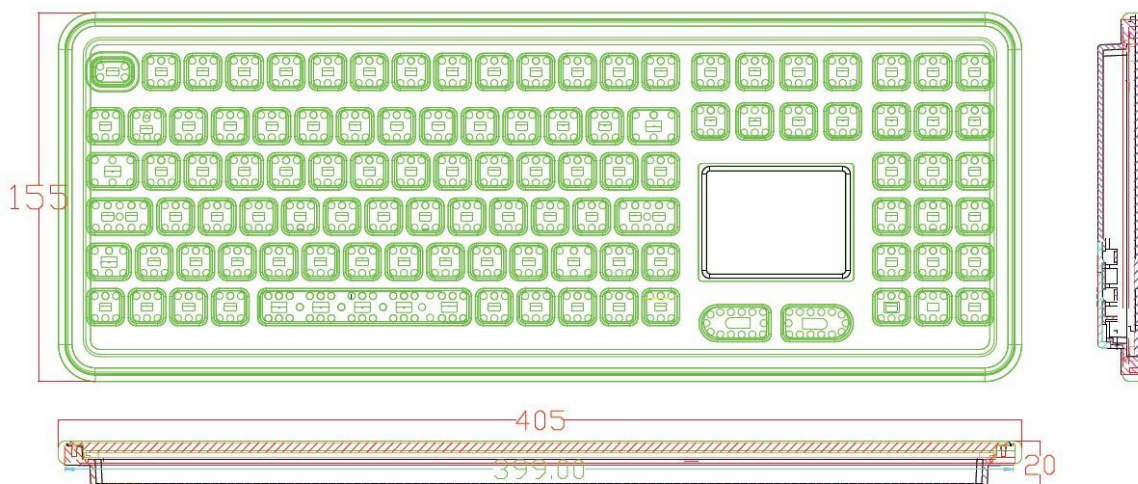



## PRI-KYB-M62NKP-AC

**Description:** IP65 rated ruggedized industrial silicone rubber keyboard with 9-12 keys, carbon-on-gold key switch technology with stroke 1.50mm for fast and accurate data input without any noise, with tactile feeling, with durable coating & antimicrobial keyboard surface withstand to most chemicals and liquids under harsh environment, front panel mounting solution, adjustable industrial backlight optional.

### APPLICATIONS:

This keypad provides full-size versatility in a rugged, compact design with the embedded convenience of an integrated numeric keypad. For working in low-light areas, it is also available with optional LED backlighting. Engineered for NEMA 4X protection from dust, water and corrosive liquids. This keyboard is ideal for use in environments ranging from manufacturing to material handling to medical settings. Its numeric pad allows for easy data entry.

**MEDICAL:** lab, hospital, clinic, dental, such as carts, diagnostic equipments, operation rooms, dialysis centers etc;

**MATERIAL HANDLING:** mobile keyboard, data entry, assembly line etc

**MILITARY:** Army, Navy, Air force

**INDUSTRIAL:** Industrial automation, pharmaceutical, oil and gas, food and beverage, clean or dirty manufacturing environments, warehouses

**OTHER INDUSTRIES**



**PRI-KYB-M62NKP-AC-9**

- **Number of Keys:** 9
- **G.W.:** 0.60 kgs
- **Dimensions:** 62.01mmx139.00mm (front panel)



**PRI-KYB-M62NKP-AC-12**

- **Number of Keys:** 12
- **G.W.:** 0.80 kgs
- **Dimensions:** 62.01mm x 165.06(front panel)

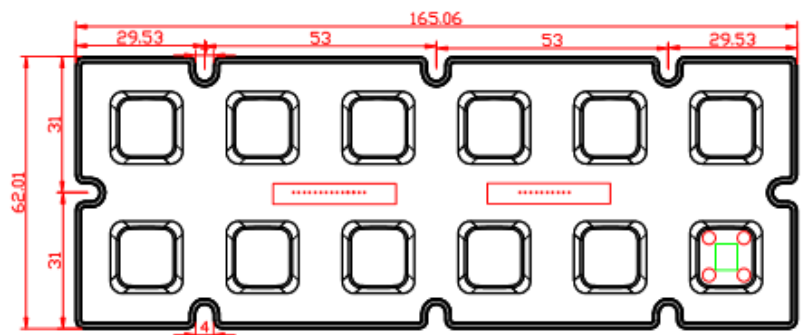
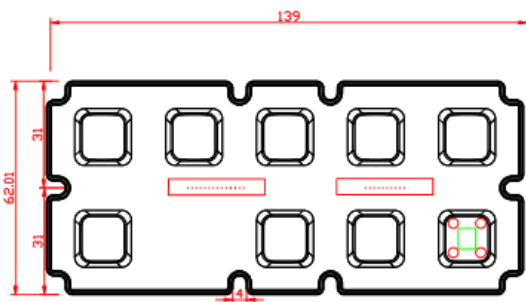

## PRI-KYB-M68NKP-AC

**Description:** IP65 rated ruggedized industrial silicone rubber keyboard with 16 keys, carbon-on-gold key switch technology with stroke 1.50mm for fast and accurate data input without any noise, with tactile feeling, with durable coating & antimicrobial keyboard surface withstand to most chemicals and liquids under harsh environment, front panel mounting solution, adjustable industrial backlight optional.

### APPLICATIONS:

This keypad provides full-size versatility in a rugged, compact design with the embedded convenience of an integrated numeric keypad. For working in low-light areas, it is also available with optional LED backlighting. Engineered for NEMA 4X protection from dust, water and corrosive liquids. This keyboard is ideal for use in environments ranging from manufacturing to material handling to medical settings. Its numeric pad allows for easy data entry.

**MEDICAL:** lab, hospital, clinic, dental, such as carts, diagnostic equipments, operation rooms, dialysis centers etc;

**MATERIAL HANDLING:** mobile keyboard, data entry, assembly line etc

**MILITARY:** Army, Navy, Air force

**INDUSTRIAL:** Industrial automation, pharmaceutical, oil and gas, food and beverage, clean or dirty manufacturing environments, warehouses

**OTHER INDUSTRIES**

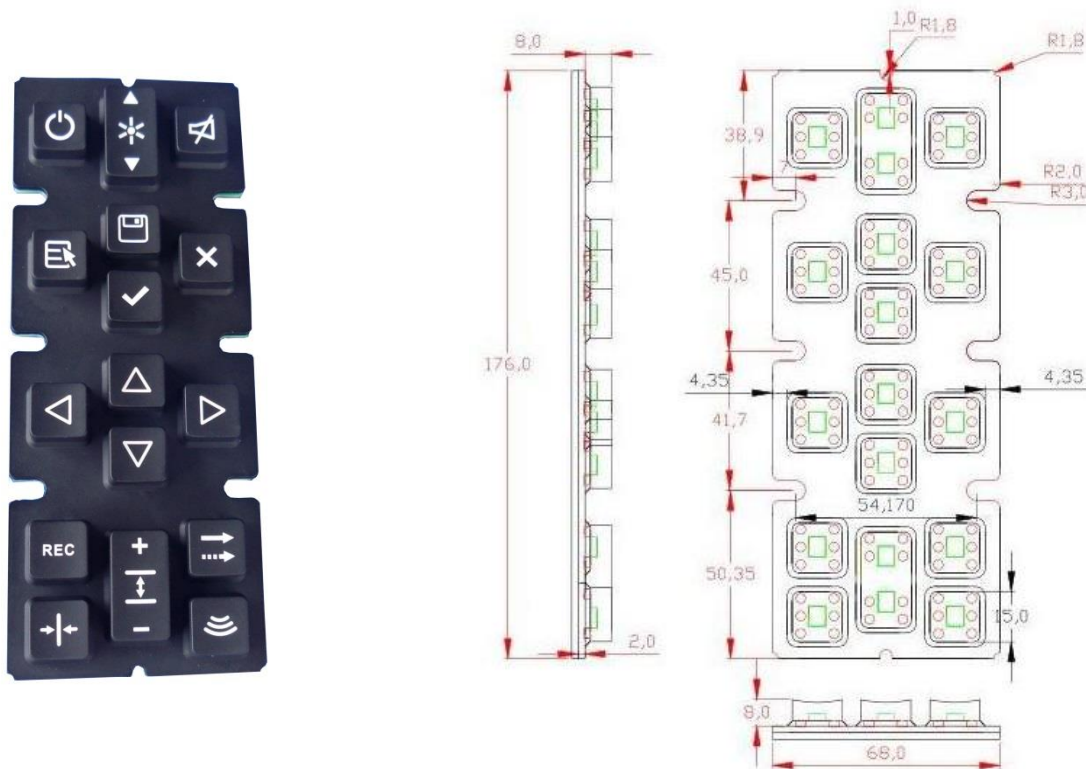

- **Number of Keys:** 16
- **G.W.:** 0.60 kgs
- **Dimensions:** 68.0mm x 176.0mm (front panel)